

## CFD STUDY CONCERNING THE UNDERBODY COMPONENTS INFLUENCE ON TOTAL DRAG FOR A TERRAIN CAR

Angel Huminic, Adrian Șoica

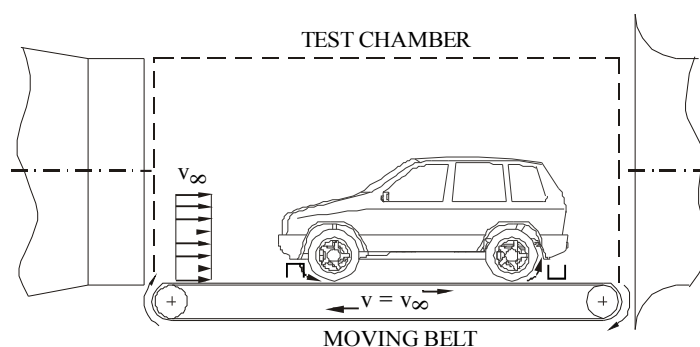
Transilvania University of Brasov - RO, Faculty of Mechanical Engineering,  
angel.h@unitbv.ro, a.soica@unitbv.ro

### ABSTRACT

In this paper, using a prototype of terrain vehicle as example, are studied the contribution of the underbody geometry on total drag using the facilities offered by a professional CFD code, namely ANSYS Flotran. These can provide solutions for the optimization of the body of vehicles, even in a very early design stage, the aerodynamic design process being accelerated. The present contribution is a companion paper of Huminic (2004).

### 1. INTRODUNCTION

The goal of this paper is the evaluation and the emphasising of the drag of the underbody geometry of a road vehicle using numerical methods. For this study were used the some CFD analyses, as presented in [3], where were taking into consideration the relative motion between vehicle and road and also the rotation movement of the wheels, according with the moving (friction) wall method [1] (see Figure 1).



**Fig. 1 – The moving wall method**

The analyses were performed in steady state, adiabatic, turbulent conditions, for a constant density of the air  $\rho = 1.205 \text{ kg/m}^3$ , for five Reynolds number (small to higher) as follow:  $Re_1 = 2.302 \cdot 10^6$  ( $v_{\infty 1} = 30 \text{ km/h}$ ),  $Re_2 = 4.605 \cdot 10^6$  ( $v_{\infty 2} = 60 \text{ km/h}$ ),  $Re_3 = 6.908 \cdot 10^6$  ( $v_{\infty 3} = 90 \text{ km/h}$ ),  $Re_4 = 9.212 \cdot 10^6$  ( $v_{\infty 4} = 120 \text{ km/h}$ ) and  $Re_5 = 11.515 \cdot 10^6$  ( $v_{\infty 5} = 150 \text{ km/h}$ ). A modified  $k-\varepsilon$  turbulence model was used, new  $k-\varepsilon$  elaborated by Shin [5] combined with Van Driest walls treatment model, according with previously experience [2], [3].

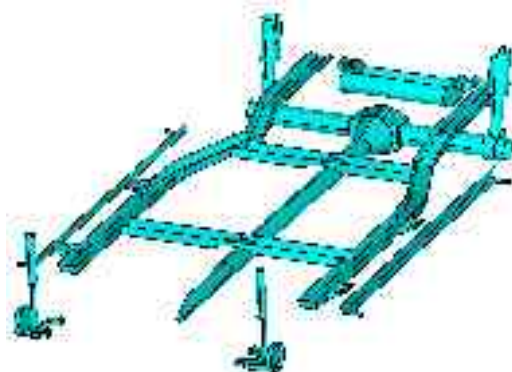
## 2. GEOMETRICAL MODEL

The body surface of the studied vehicle (ARO 246, experimental model of ARO SA, Romanian automotive company), was drawn as CAD data, with the aid of a professional software-package, Pro-ENGINEER 2000i<sup>2</sup> (see Figure 2). The exterior of vehicle was very carefully reproduced, with the exception of the air-cooling vents, which are closed.

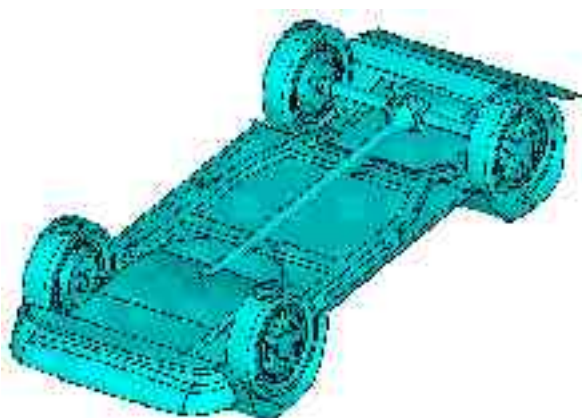


*Fig. 2 – CAD model*

The under-body geometry was simplified. In this sense the very small features were removed. Details of these can be showed in Figures 3 and 4.



*Fig. 3 – Structural elements of underbody geometry*



*Fig. 4 – Evaluated underbody geometry*

Were tacked into consideration the medium and large assembly, as chassis with reinforcing frames and bracing rib, front and rear main suspensions, elements of rear

transmission and driving axle, guard screen of the front axle and also some components of the exhaust of burnt gasses, respectively the rear silencer. Also, the exterior surfaces of the wheels and them shells were very carefully reproduced in order to obtained the realistic results, as much as possible.

### 3. RESULTS AND CONCLUSIONS

The features of the used ANSYS versions allow calculating the aerodynamic forces that are acting over the vehicle, as presented previously. Was evaluated the drag of the global underbody geometry  $D_{ub}$ , as presented in Figure 4 and also the drag of its main components: wheels each separately, front  $D_{fw}$  and rear  $D_{rw}$  and also global  $D_{ws} = D_{fw} + D_{rw}$  and the drag of unprotected (from aerodynamic point of view) structures  $D_{us}$ , as presented in Figure 3. The obtained results are presented numerically in the table no. 1 and 2 and in a graphical form in Figure 5.

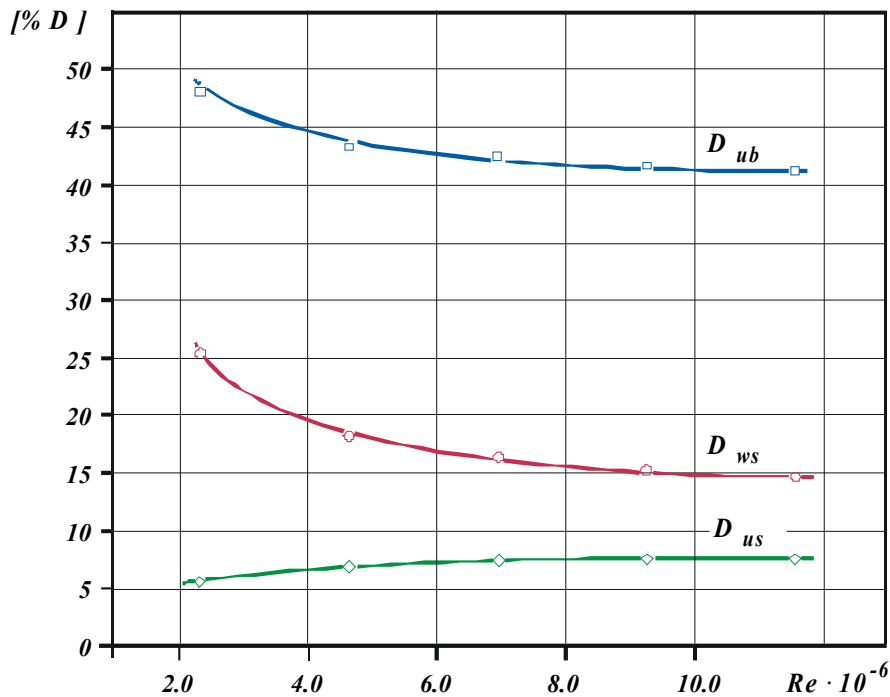


Fig. 5 – Variations of  $D_{ub}$ ,  $D_{ws}$  and  $D_{us}$  versus  $Re$

Table 1

$v$	[km/h]	30	60	90	120	150
$D_{ub}$	[%D]	48.06	43.20	42.45	41.65	41.20
$D_{ws}$	[%D]	25.28	18.14	16.33	15.14	14.60
$D_{us}$	[%D]	5.48	6.81	7.37	7.46	7.52

Table 2

v	[km/h]	30	60	90	120	150
$D_{fw}$	[% $D_{ub}$ ]	29.90	23.46	21.19	20.06	19.47
$D_{rw}$	[% $D_{ub}$ ]	22.70	18.53	17.28	16.28	15.97
$D_{ws}$	[% $D_{ub}$ ]	52.60	41.99	38.47	36.35	35.43
$D_{us}$	[% $D_{ub}$ ]	11.41	15.77	17.38	17.91	18.24

As can be observed, for analysed vehicle, with a large ground clearance and many unprotected components, the influence of the global drag of the underbody geometry is a significant one, more than 40%. This percentage is a higher one for lower to medium velocity and is decreasing for higher velocity.

A major percent from drag of underbody is due to the wheels, considered in motions, around 40% from underbody drag. The wheels influence decrease with velocity to a value of  $\sim 15\%$ . An opposite behaviour has the unprotected elements of structure. The drag of these  $D_{us}$  is rising with the velocity, because they represent surfaces of impact and in the same time sources of detachment and taking-off of the boundary layer. This can be observed by plotting the variation of wall shear stress distribution,  $\tau_w$ , for a field of 0.0 – 0.1, when is happening the taking-off phenomena.

As can be shown in Figures 6 to 10, the affected areas, of the vehicle underbody and also for entire vehicle, by the detachment of the air are becoming smaller with the increasing of velocity. The CFD evaluation of the main structural elements, which have importance on the aerodynamic behaviour of vehicles, can have as result specific solutions for improving of the performances of the cars, even in a very early design stage and lead to optimising of aerodynamic behaviour of the vehicle.

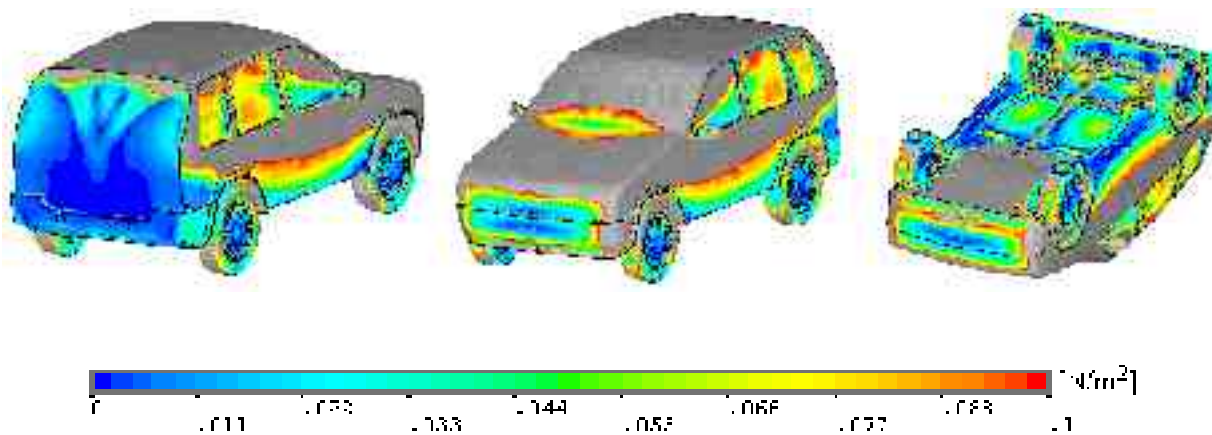


Fig. 6 - Wall shear stress distribution  $\tau_w$ ,  $v = 30$  km/h



Fig. 7 - Wall shear stress distribution  $\tau_W$ ,  $v = 60 \text{ km/h}$



Fig. 8 - Wall shear stress distribution  $\tau_W$ ,  $v = 90 \text{ km/h}$



Fig. 9 - Wall shear stress distribution  $\tau_W$ ,  $v = 120 \text{ km/h}$

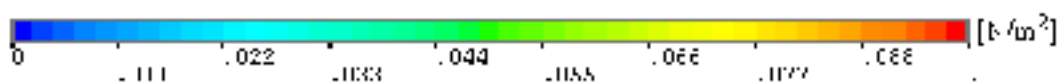


Fig. 10 - Wall shear stress distribution  $\tau_W$ ,  $v = 150 \text{ km/h}$



To this end, we mention that the CFD evaluation of the main structural elements, which have importance on the aerodynamic behaviour of vehicles, can have as result specific solutions for improving of the performances of the cars, even in a very early design stage and lead to optimising of aerodynamic behaviour of the vehicle.

## REFERENCES

- [1] Sumatran V., "Vehicle aerodynamics", SAE Inc, PT-49 USA, 1996, ISBN 1-56091-594-3.
- [2] Huminic Angel, Chiru Anghel, "Comparative Study of Different Ground Simulation Techniques used in Numerical Investigation of Vehicle Aerodynamics", Bucharest Politehnica Press, The 7<sup>th</sup> International Conference, FUEL ECONOMY, SAFETY and RELIABILITY of MOTOR VEHICLES, ESFA 2003, Volume 1, ISBN 973-8449-10-3
- [3] Huminic A., Chiru A., "Ground Effect in Design of Vehicle", FISITA 2004 World Automotive Congress, on CD, F2004F130.
- [4] Huminic A., CFD Study Regarding the Influence of the Underbody Geometry on Total Drag for a Vehicle, CONAT 2004 Congress, Brasov.
- [5] \*\*\*, "ANSYS SAS Revision 5.6", ANSYS, Inc., Southpointe, Canonsburg, USA, 1999.