

DEVICE OF PLASTIC SUPERFICIAL DEFORMATION BY VIBRO- HARDENING

Stelian CEOBANU, Octavian PRUTEANU

University of Iasi, Faculty of Machine Manufacturing, pruteanu@tcm.tuiasi.ro

Key words: superficial plastic deformation, vibro - hardening, roughness surface

Abstract: In this paper the authors present a device of plastic superficial deformation by vibro - hardening, imagined in the aim of hardening of the superficial layer as well as the improvement of the quality of the surfaces. The presentation of the device is accompanied by experimental results.

1. INTRODUCTION

The superficial plastic deformation by vibro - hardening, as a process of treatment of superficial mechanical metallic surfaces, contributes not merely to the improvement of the physical features of the part manufactured, but also to the achievement of a certain degree of finishing.

The finish surfaces of a metallic part, through cold plastic deformation, are based on the movement of the superficial layer of the metal, under the action of forces of pressure, from the prominent zones, towards the zones of equalization, respectively to standardize the surface.

The cold plastic deformation has as its next consequences material hardening, which supports a material cold hardening process, obtaining of a new texture, the intake in the body of a remnant stress, the modification of the temperature of the body, production of a transformation of the phase as well as the modification of material properties.

2. THE PRESENTATION OF THE DEVICE

The experimental equipment consists of a machine tool, devices and a cementing outfit for processing through DPS, devices for the measurement of forces, devices for the measurement of roughness parameters, devices for the determination of the hardening of the superficial layer.

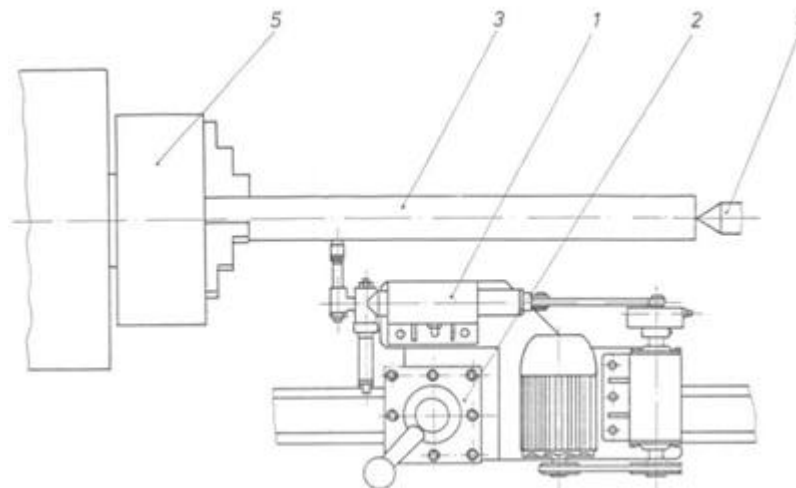

Figure 1. The scheme of the device of processing by DPSR

Where: 1 - the device of process;
 2 - support ;
 3 - the piece of manufacturing;
 4 - peak of centering;
 5 - universal head of catch

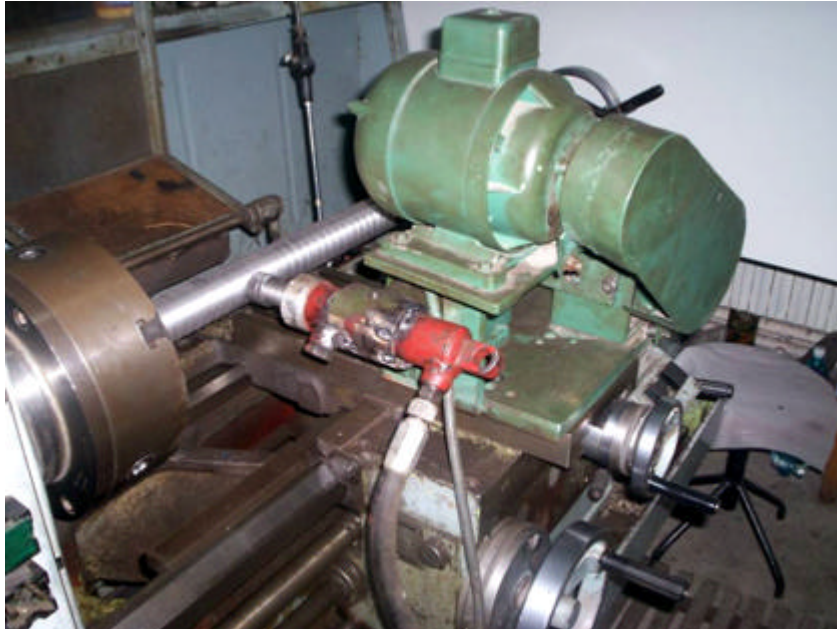

Figure 2. Device of processing by DPSR

Force of press the element of deformation is obtained by waterworks (fig. 3) which permits maintain the constant on the time this processing. Before the beginning of the thing, whole the system of transmit of the force are calibrated.

In the figure 3 is presented a head of run with the ball. The bearing 6 is fixed in the body 1 of head of run by bolt 5. On bearing is bridged into the contact an which ball 7 is maintained in position of thing bush 3 with bezel for balls, what bushes can be changed depending on the diameter of the ball.

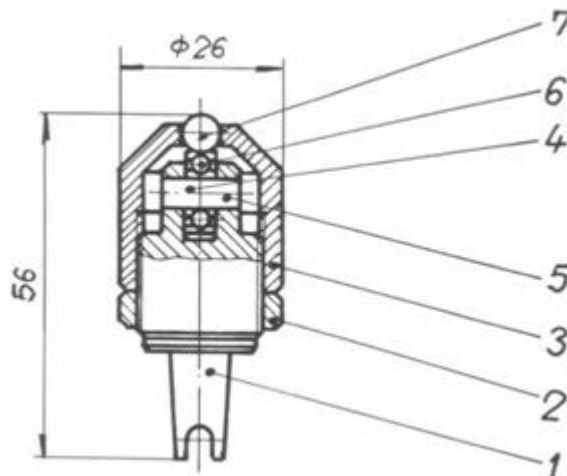

Figure 3. Head of run with ball

The stable position temporarily thing is assurance through the clutch of tuning 2. Force of pressure for were projected the device is contained between 20 and 1000 N so that to is covered whole the valuable beach as much in the case of the use of the balls(100-1000 N) and, the race of thing can be adjusted between 0, 3 and 7 mm.

For the realization experimental researches they achieved for each guys of material check bar for experimentation by exterior cutting of finish having the length of 10 mm and the rugosity the initial of approximate 6 μm .

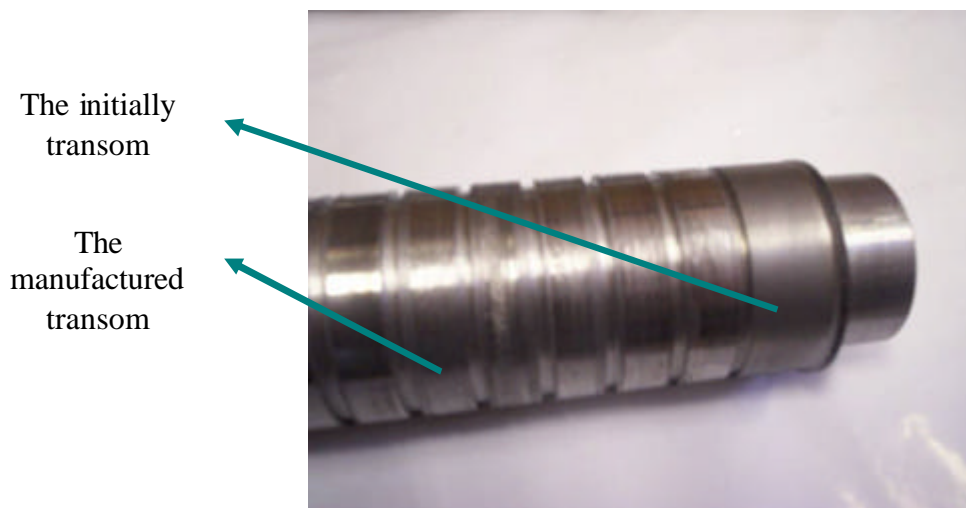

Figure 4. Mode of materialization by surfaces

The cold hardening effective depends on the material nature, tensional to, formally etc. An elemental role gambles it the choice of the regime of hardening, the maximum effect depending on concrete conditions in which operates the piece

Deform of a body below the act of exterior forces presupposes the modification of the form and the sizes of the body. Thus the remnant deformation which appears in the temporarily the process of vobro-hardening and innards of exterior revolution is obtained with the relation 1:

$$\Delta D = D_0 - D \quad (1)$$

Where: D_0 are the diameter of semi product;
 D – the diameter after process.

3. CONCLUSIONS

As much as part as the passive methods, quotients and to one active, the initial effect about surface process is a trace of a tool (the mark), carry then transformed in a trickles of what marks cover his partial this total the surface. Thus, is enforced the of a charterage different attentions of the mode of drive the process, when you wanted the procurance micro-geometrics enforced.

Pursuant to of obtained a degree of strong cold hardening of material to the level of superficial which drove to appears delaminating of material and therefore, to embitterment material quality, take off the experimental results of the suggested initially aim obtained a high-quality a material surface of the values by force of deformation were decrease to 10 daN and respective 30 daN beside one considerate initially 50 daN and 100 daN,

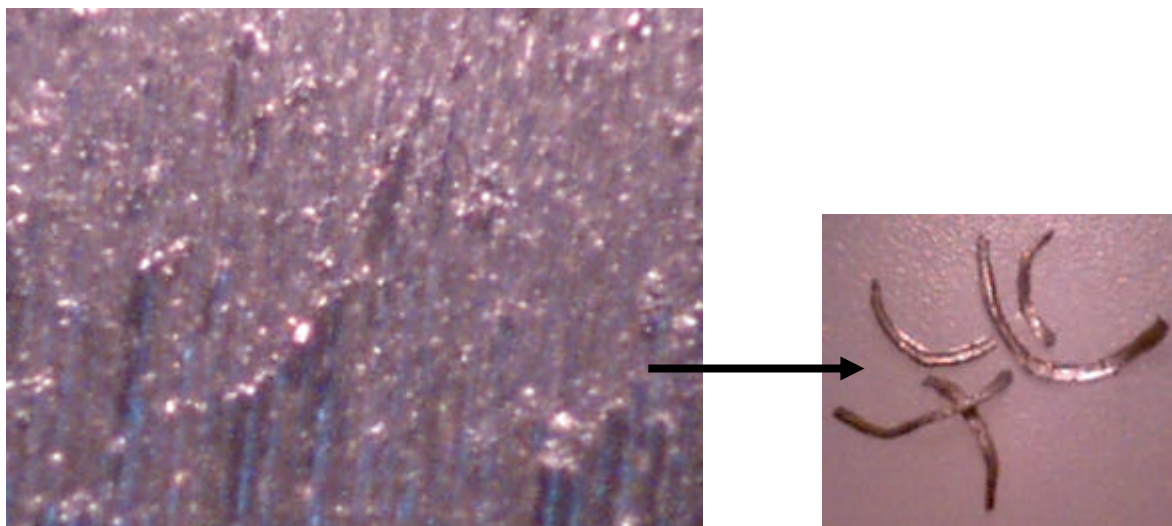
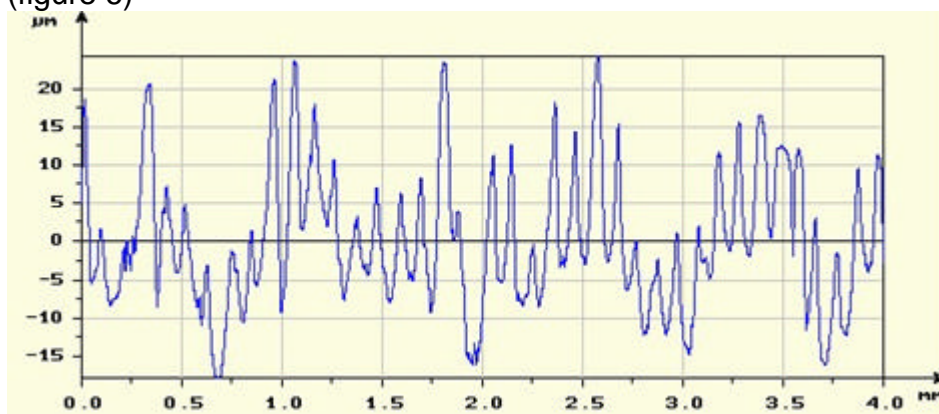
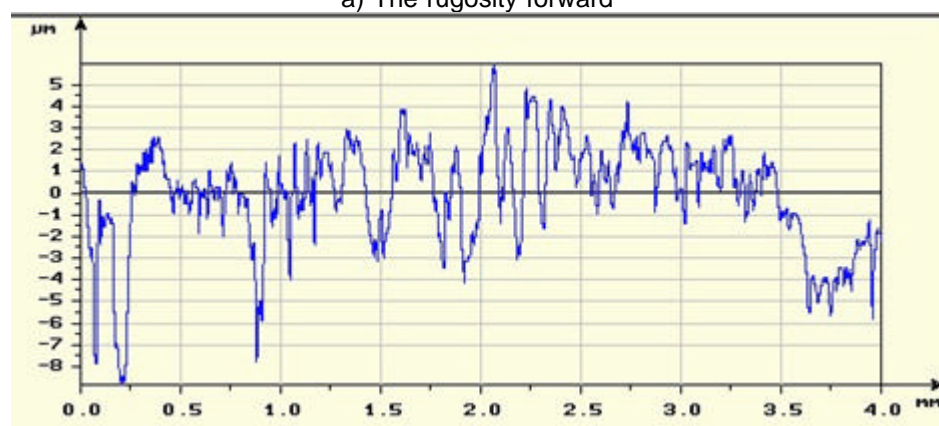

Figure 5. The delaminating of material

Through comparison by rugosity forward and after remaking is noticed a decrease a these value (figure 6)



a) The rugosity forward



b) The rugosity after

Figure 6. The value of rugosity

Bibliography

1. Ionescu, R., Amarandei, D. Planificarea experimentelor eficienta si calitate. Bucuresti, Editura AGIR, 2004;
2. Musca, G., Amarandei, D. Ionescu, R. Experimentarea, modelarea si optimizarea produselor si proceselor, Editura Tehnica, Chisinau, 1998
3. Schnakovszky, C. Modelarea si monitorizarea activitatilor logistice în sistemele de productie, Ed.Tehnica-Info, Chisinau, 2000, pag.16-20.