

THE MEASUREMENT OF THE STRAIGHTNESS IN THE CASE OF LONG GUIDEWAYS, USING MODERN MEASUREMENT METHODS, NAMELY, THE LASER

PhD. Eng. Flavius A. ARDELEAN
University of Oradea, aflavius@uoradea.ro

Key words: straightness, deviation from straightness, interferometry, measurement, laser, guideway

Abstract

Many times, in practice, there are times when long, heavy parts need to be extremely accurately aligned. Be they lathes, milling machines or grinding machines, they have to function at the highest precision that is why the setting into operation needs to be performed in optimal conditions. The guideways that will take the slides with the parts set for processing, which will accurately ascend or descend the milling end in the working point, will be set with the help of the laser.

1. INTRODUCTION

The straightness of the machine tools' guideways is one of the most difficult problems when it comes to setting them into operation, because the functioning accuracy in exploitation depends on the future working precision of the machine tool.

The deviation from straightness, which represents the deviation from an hypothetical straight line and which is considered to be the difference between two tolerances, superior and inferior, which allows a piece to work, has major consequences in the future running of the machine tool.

The deviation from straightness is a shape deviation, representing the deviation of the actual side-face in comparison with the adjoining line shape (figure 1).

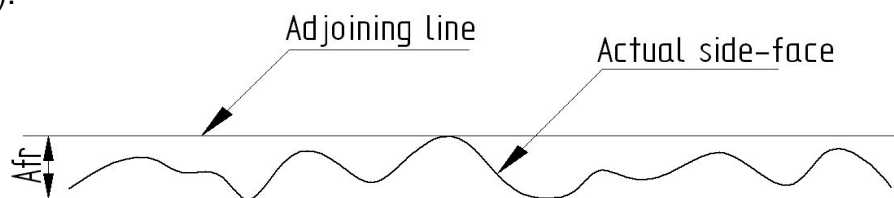

Fig. 1 The straightness deviation diagram

The straightness greatly depends on the condition of the surface to be measured, on its roughness. That's why the surface should be processed by grinding – if it is sufficient - or it should be scraped.

The prepared surface to be measured is measured to determine the straightness and flatness – if it's required. There are two planes on which the

straightness measuring are made: one it's on a vertical plane and the other on a horizontal plane (meandering).

The classical measurements use straightness lineal (made from cast iron or black granite), dial indicators, parallel gauges, checking and tracing plateau. The checking lineal is built in three types, eleven shapes and six accuracy class. The measuring methods are: lights aperture method, paint mark method, dimensioning comparison method, optical method.

The lineal straightness with active edges has different dimensions and they use the light aperture method. The lineal straightness with active surfaces uses the light aperture method or the paint mark method. The straightness control of the big and heavy surfaces is performed with the checking lineal and parallel gauges aid, as shown in figure 2. With the help of another parallel gauge the distance between the checking lineal and the piece surface is measured, in different points. The straightness deviation equals the difference between the biggest measured distance and the nominal length of the parallel gauge on which, the checking lineal is standing.

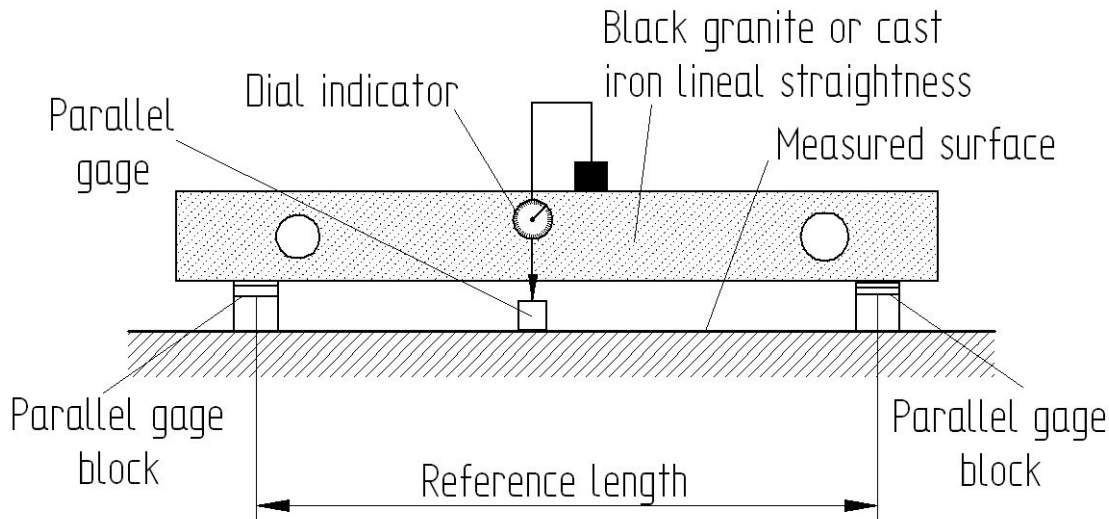

Fig.2 Measuring the straightness with the checking lineal and the parallel gauge diagram

2. THE PRINCIPLE OF INTERFEROMETRY

Interferometry is the technique of superimposing (interfering) two or more waves, to detect differences between them. Interferometry is applied in a wide variety of fields, including astronomy, fiber optics, engineering metrology, optical metrology, oceanography, seismology, quantum mechanics and plasma physics. Interferometry works because two waves with the same frequency that have the same phase will add to each other while two waves that have opposite phase will subtract. Typically, in an interferometer, a wave is split into two (or more) parts, which travel different paths, and the parts are then combined to create interference. When the paths differ by an even number of half-wavelengths, the superposed waves are in phase and interfere constructively, increasing the amplitude of the output wave. When they differ by an odd number of half-

wavelengths, the combined waves are 180° out of phase and interfere destructively, decreasing the amplitude of the output. Thus anything that changes the phase of one of the beams by only 180° , shifts the interference from a maximum to a minimum. This makes interferometers sensitive measuring instruments for anything that changes the phase of a wave, such as path length or refractive index. [2]

A principle diagram of a laser interferometer [1] is shown in figure 3, where some annotations were made: S - the laser radiation source; L – follower rest with the dispersion role of the fascicle emitted by the laser before it entered in interferometer; O_r – reradiated mirror; L_d – divided blade; O_b – objective; E – screen; FE – photoelement.

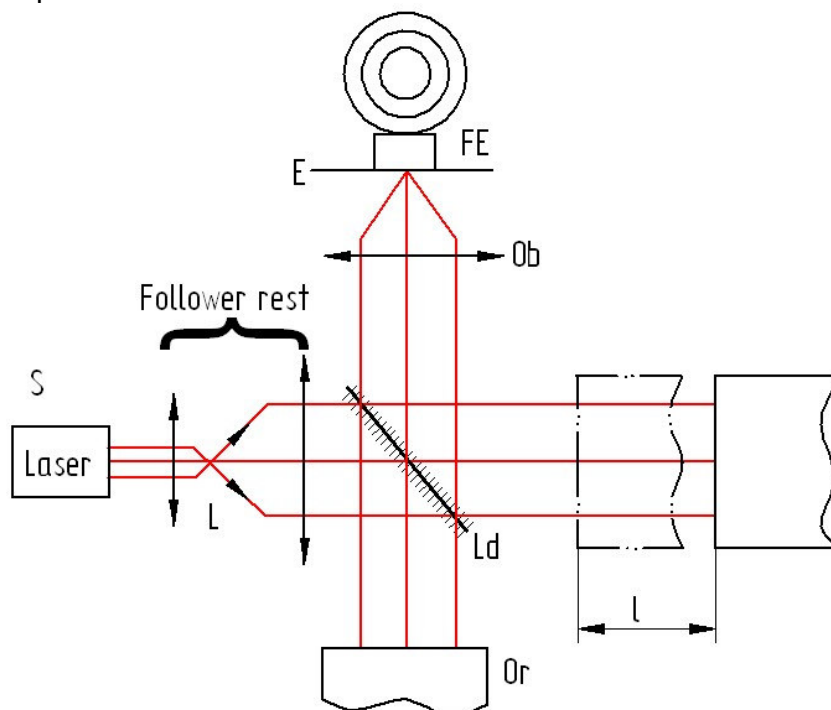

Fig. 3 The principle diagram of a laser interferometer

3. LONG GUIDEWAYS STRAIGHTNESS MEASUREMENT USING THE LASER

Straightness measurements show bending or overall misalignment in the guideways of a machine. This could be the result of wear in these guideways, an accident which may have damaged them, or poor machine foundations that are causing the axis to bow. Straightness error will have a direct effect on the positioning and contouring accuracy of a machine. The laser system measures the machine straightness accuracy and repeatability by moving the machine to a number of target positions and measuring the straightness deviations [3], [4]. A typical system set-up for measuring straightness errors is shown in figure 4.

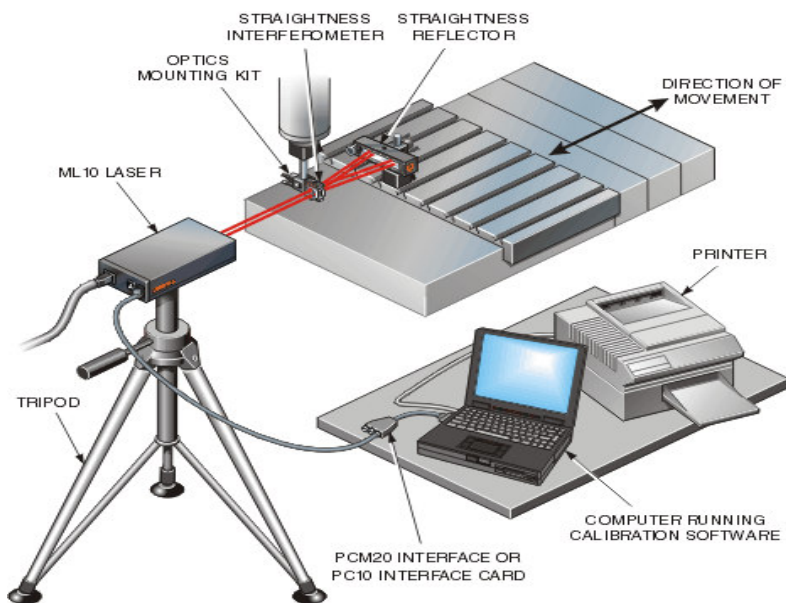

Fig. 4 Typical system set-up for measuring straightness [4]

The machine tool on which the measurements were made was a milling machine FLP2200 and the laser tool was a ML10 Renishaw. Both, the milling machine and the laser tool, are of the same company, SC Emsil Techtrans SRL from Oradea. This machine tool was supposed to be operational and it needs to be aligned at a high precision due to the STAS requirements. The particularity of the milling machine was the long stroke of the slide (approximately 20 m) and, because of the fact that one guideway was in "V" shape, the measurements were made in two planes, vertical and horizontal. The straightness requirements of the STAS were 0.05 mm in vertical plane and 0.07 mm in horizontal plane for the guideways between 11400 a 21400 mm range.

After the measurements and all the adjustments were made, the machine became operationally adequate, in good condition and at the barred parameters.

In the pictures below (fig. 5), some aspects from the moment when the measurement were taken from the milling machines are shown.



a

b

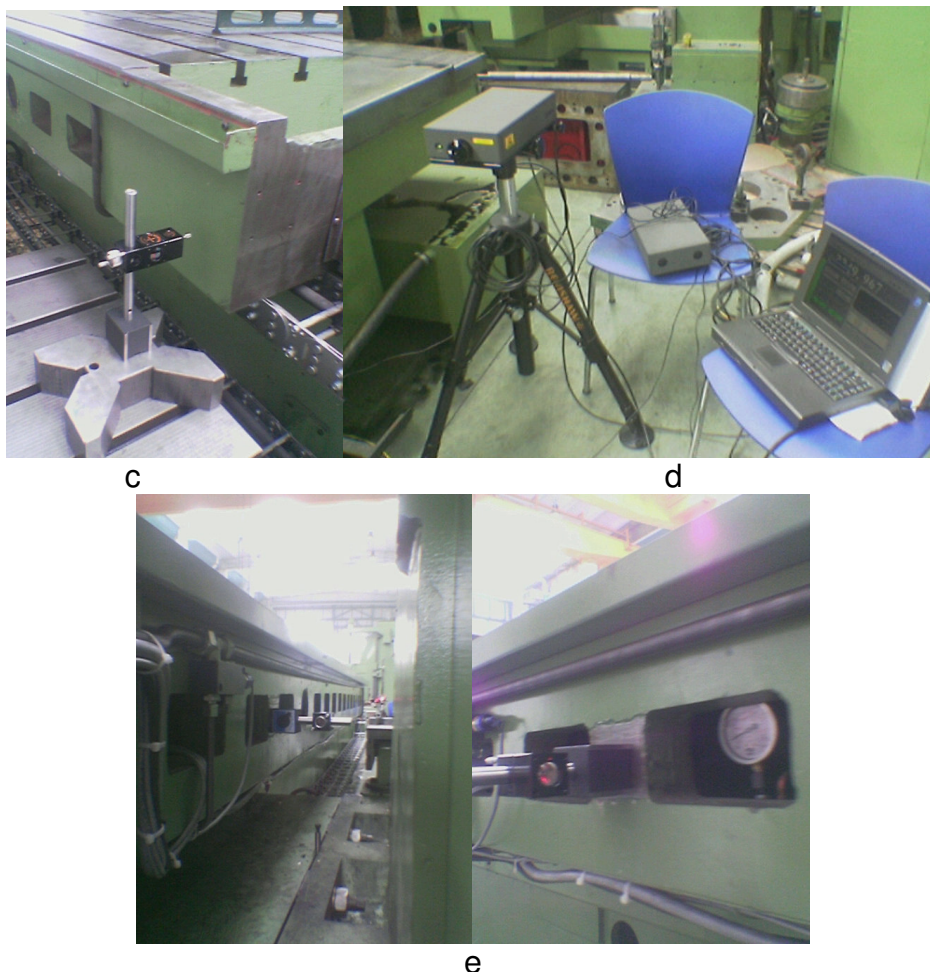

Fig. 5 Certain aspects from the time when the FLP2200 was measured with the ML10 Renishaw

4. CONCLUSIONS

1. Straightness measurement could be made by classical methods but these are less accurate and they need repeated repositioning of the lineal which is difficult to perform.
2. The measurement methods with modern devices, namely the laser, is faster, more accurate, being able to measure the straightness on long distances.
3. With the help of the laser certain diagrams can be obtain which will help later on to adjust the machine tool.

BIBLIOGRAPHY

1. Ștețiu, E. C., Oprean, C., Măsurări geometrice în construcția de mașini, Ed. Științifică și Enciclopedică, București, 1988
2. ****Laser interferometer LSP30, User manual
3. ****ML 10 Renishaw, Laser system manual
4. ****www.wikipedia.com
5. ****www.emsil.ro