

DEVELOPMENT OF CONICAL SURFACES USING CAD PROCEDURES

Mircea LAZAR

University of Pitesti, Faculty of Mechanics and Technology,
Department of Technology and Management
e-mail: mircea@lzt.ro

Keywords : development, transformed, generatrix, section curve

Abstract: It is known that in technical drawing when doing rectangular representations of solids, especially when doing representation of car bodies, the development of curve surfaces is of prime importance. In order to make a development as correct as possible of some curve surface, it is necessary to determine a sufficient number of current and particular points of the directory curve or of the section curve. Taking these into account, the paper proposes development constructions of some conical curve surfaces, side surfaces of some cones arranged in any position or of some cone frustum, using AUTOCAD. Construction of developments is based on theoretical notions of perspective geometry, but the graphic representations are done using CAD procedures.

1. Introduction

The surfaces development of a geometric solid is the representation in which all the outer points of the solid are brought on a plane. The obtained plane figure is called development or transformed by developing a geometric solid. The geometric solids surfaces which are frequently encountered in engineering are developable or undevelopable surfaces. The solids with developable surfaces are the polyhedrons, cylinder-cone solids or combinations between them; the undevelopable surfaces are the rotation bodies.

In order to build the development of cone bodies there are specific principles and methods and it is necessary for the following to be known:

- real size of generators;
- real size of the section curve in the case of cone frustums;
- real size of the base(bases);

Depending on the situation, the development of a geometric solid is done using graphical methods with the help of perspective geometry elements, but the graphical representation within the paper was done using AutoCAD.

In the case of conical solids, we consider a polygon with n sides inscribed in the diretrix curve. For example, the following are obtained: a pyramid with n sides inscribed in cone, a prism with n sides inscribed in a cylinder, and so on. If in the polygon inscribed in the diretrix curve, the number of sides tends to infinity, the lengths of all the polygon sides tend towards zero. In this case, the surface of the conic solid is approximated with the surface of inscribed polyhedron solid inscribed.

In order to build a development of some surface, it is necessary to determine a sufficient number of current and particular points of this one.

Further on, within this paper, the development of a cone and of a cone frustum in various variants will be done using Auto-CAD type procedures for graphic representation.

2. Development of some cone surface

In order to do a cone development, a pyramid inscribed in the respective cone is considered, having the common tip with the cone's; the base is a n lateral sides polygon, so with n lateral sides.

Because the number of lateral sides tends to infinity, the lateral surface of the cone is approximated by the pyramid lateral surface. It results that, when developing the lateral surface of the cone it is needed a number as much as possible (sufficient) of generators in real dimension. Their number is determined by the precision of cone development construction. Some generators are in real dimension on one projection, in the form of contour lines, front lines or profile lines. In the case of the other generators, a level or front rotation will be done until they become parallel with a projection plane. To simplify the construction, the rotation axis is chosen through the cone tip.

The development of directrix curve is also a curve, where the lengths of directrix curve arcs are approximated with the sides of inscribed polygon. The construction of cone development is done by developing the pyramid inscribed in cone, where the polygon base tips are linked by curve arcs, approximating the lengths of directrix curve arcs with the inscribed polygon sides.

We consider an oblique circular cone $\{C(I, S)\}$, with base of $I(i, i')$ centre in the vertical plane of V projection and some $S(s, s')$ tip, represented just like in Figure 1. The cone is projected on $[H]$, after the apparent contour which contains the sa, sb horizontal projections of SA, SB generators and the horizontal projections of the base, ab line segment. The cone projection on $[V]$ has the apparent contour made up of the $s'e', s'f'$ vertical projections of SE, SF generators and the vertical projection of e', g', a', k', f' directrix curve arc.

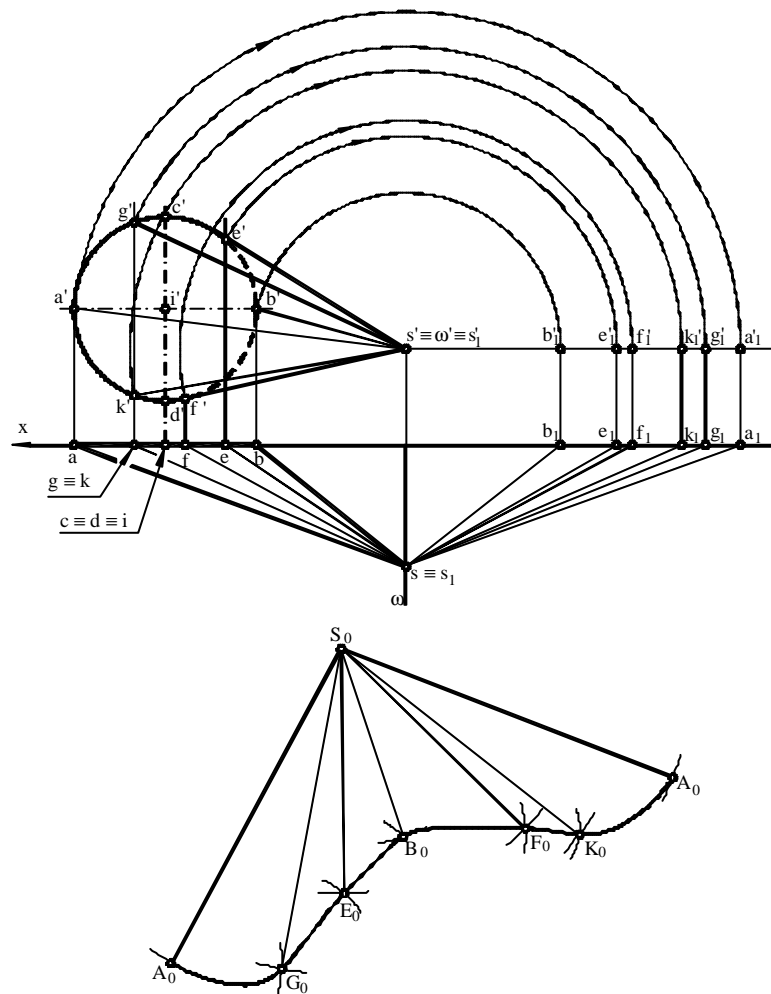

Fig. 1. Development of a oblique cone – constructive elements and development

As the cone base is in \underline{V} plane, it is projected in its real dimension on this projection plane. In order to find out the real size of the generators, their front rotation is done, where the rotation axis is the line with $\Omega(\varpi, \varpi')$ end, drawn through the cone tip (fig. 1). By front rotation, the generators that are any lines transform in contour lines, so on the horizontal rotated projections, the real generators sizes can be measured. After the real size of the necessary elements was found out, the lateral sides development of the inscribed pyramid are drawn (like pyramid development), successively building the lateral sides.

For example, for $\Delta S_0 A_0 G_0$ $\overline{S_0 A_0} = \overline{s'_1 a'_1}$, $\overline{S_0 G_0} \equiv \overline{s'_1 g'_1}$ and $\overline{A_0 G_0} \equiv \overline{a'_1 g'_1}$ are taken, then for $\Delta S_0 G_0 E_0$ $\overline{S_0 G_0}$ $\overline{S_0 E_0} \equiv \overline{s'_1 e'_1}$ and $\overline{G_0 E_0} \equiv \overline{g'_1 e'_1}$ are taken. We continue in the same way up to the last triangle $S_0 K_0 A_0$ with $\overline{S_0 K_0}$, $\overline{S_0 A_0} = \overline{s'_1 a'_1}$ and $\overline{K_0 A_0} = \overline{k'_1 a'_1}$ (fig.1). The $A_0, G_0, E_0, B_0, F_0, K_0, A_0$ obtained points get connected using curve arcs which approximate the respective sides (the polygon sides of the base pyramid inscribed in cone) and form a curve line, this being the development of directory curve of the oblique cone which was considered. The found points get connected by curve lines and thus the directory line is determined.

The construction of directory curve was done using Auto CAD, with *Pline* order. The *Fit* option of the *PEdit* order allows drawing through the found points a curve, interpolating grade two polygons. Thus, the directory curve which resulted through points using methods of perspective geometry has the representation shown in Figure 1.

The $A_0, G_0, E_0, B_0, F_0, K_0, A_0$ curve line has two inflexion points, E_0 and F_0 , where the curve of circle development gets changed. The inflexion points are found on the generators contained in the planes tangent to cone, perpendicular on the directory curve plane.

In this case, these planes are end planes, so the inflexion points are the tangent points of the generators of the apparent contour from $[V]$ with vertical projection of the directory curve.

3. Surface development of a cone frustum

A cone frustum is determined by sectioning some cone with some or certain plane.

Case I. Development of a cone frustum with parallel bases. If some $\{C(I, S)\}$ cone, with base a circle of $I(i, i')$ centre in the H horizontal projection plane is sectioned with a parallel plane to $[H]$, for example the N level plane, a cone frustum with parallel bases is obtained (fig. 2.).

To develop the surface of the resulted cone frustum, first of all it is needed to develop the surface of the whole cone, like it was shown in the previous chapters. Establishing the real size of the generators is done by a level rotation, where $\Omega(\varpi, \varpi')$ the rotation axis is the vertical line which contains the cone tip. Thus, for the construction of cone development, the following segments are taken:

$$\overline{s'_1 a'_1} \equiv \overline{S_0 A_0}, \quad \overline{s'_1 g'_1} \equiv \overline{S_0 G_0}, \quad \overline{s'_1 k'_1} \equiv \overline{S_0 K_0};$$

$$\overline{s'_1 f'_1} \equiv \overline{S_0 F_0}, \quad \overline{s'_1 e'_1} \equiv \overline{S_0 E_0}, \quad \overline{s'_1 b'_1} \equiv \overline{S_0 B_0}.$$

Because the plane of N section is a plane parallel to $[H]$, then the section in cone is a circle with the horizontal projection in real size and the vertical projection a line segment confounded with N_V vertical trace of the N level plane.

The current points on the section points needed to determine the section are found at the generators intersection with the N section plane. Due to the fact that $[N] \perp [V]$, the vertical projections of current points are found at vertical projections plane of generators with N_v vertical trace.

$$s'a' \cap N_v \Rightarrow 1', s'b' \cap N_v \Rightarrow 2', s'f' \cap N_v \Rightarrow 3' \dots, s'e' \cap N_v \Rightarrow 7'.$$

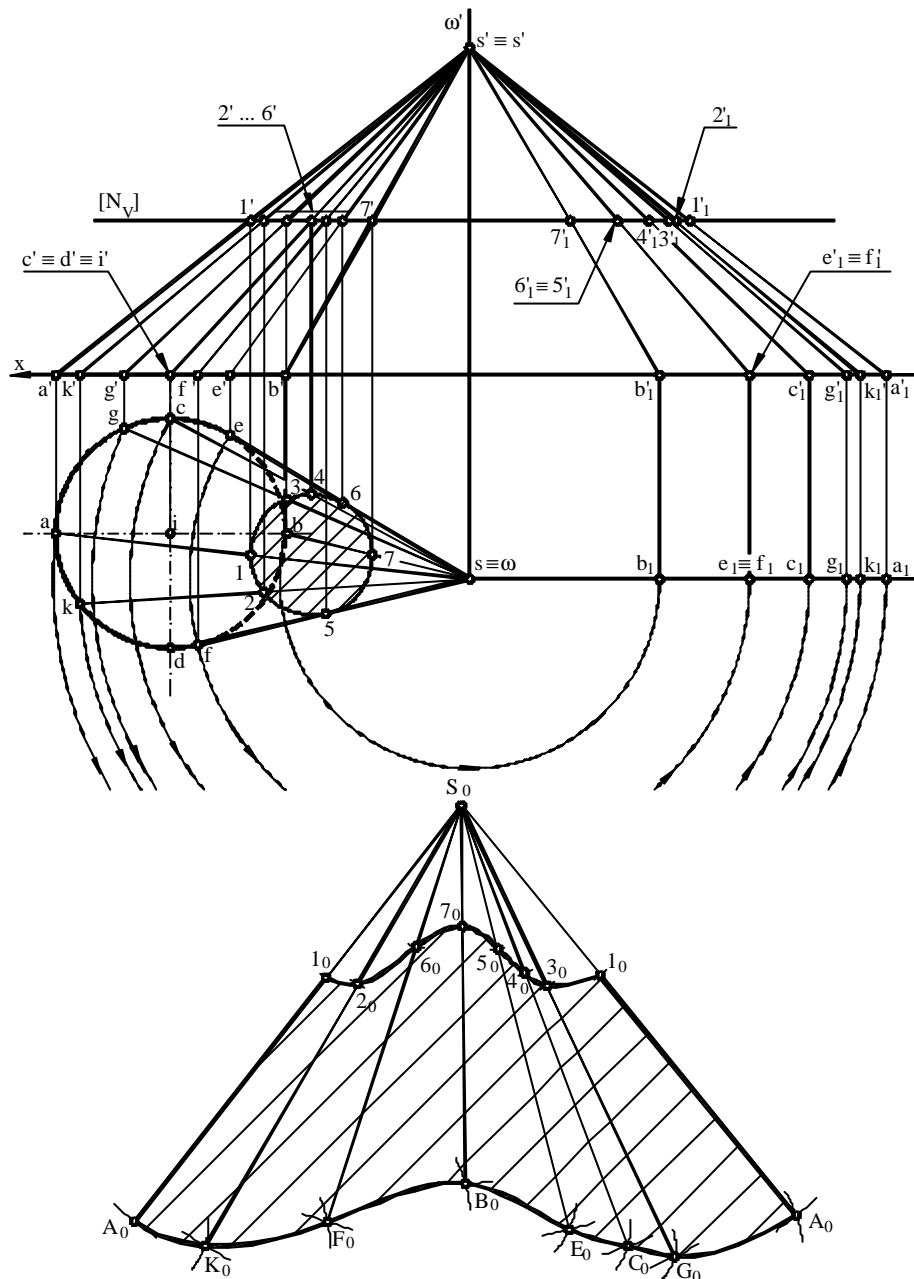

Fig. 2. Development of cone frustum with parallel bases

From the obtained vertical projections, order lines are drawn to the horizontal projections of the corresponding generators and the 1, 2, ..., 7 projections are determined.

After the cone development is constructed, on this development is drawn the development of the second base of cone frustum, i.e. the section circle.

Case II. Development of cone frustum with unparallel bases. In Figure 3, some cone $\{C(I,S)\}$ is considered, with base a circle of $I(i,i')$ centre in the horizontal plane of H projection, sectioned by a projecting plane, which is the $P(P_H, P_V)$ vertical plane.

Thus, a cone frustum with unparallel bases is obtained.

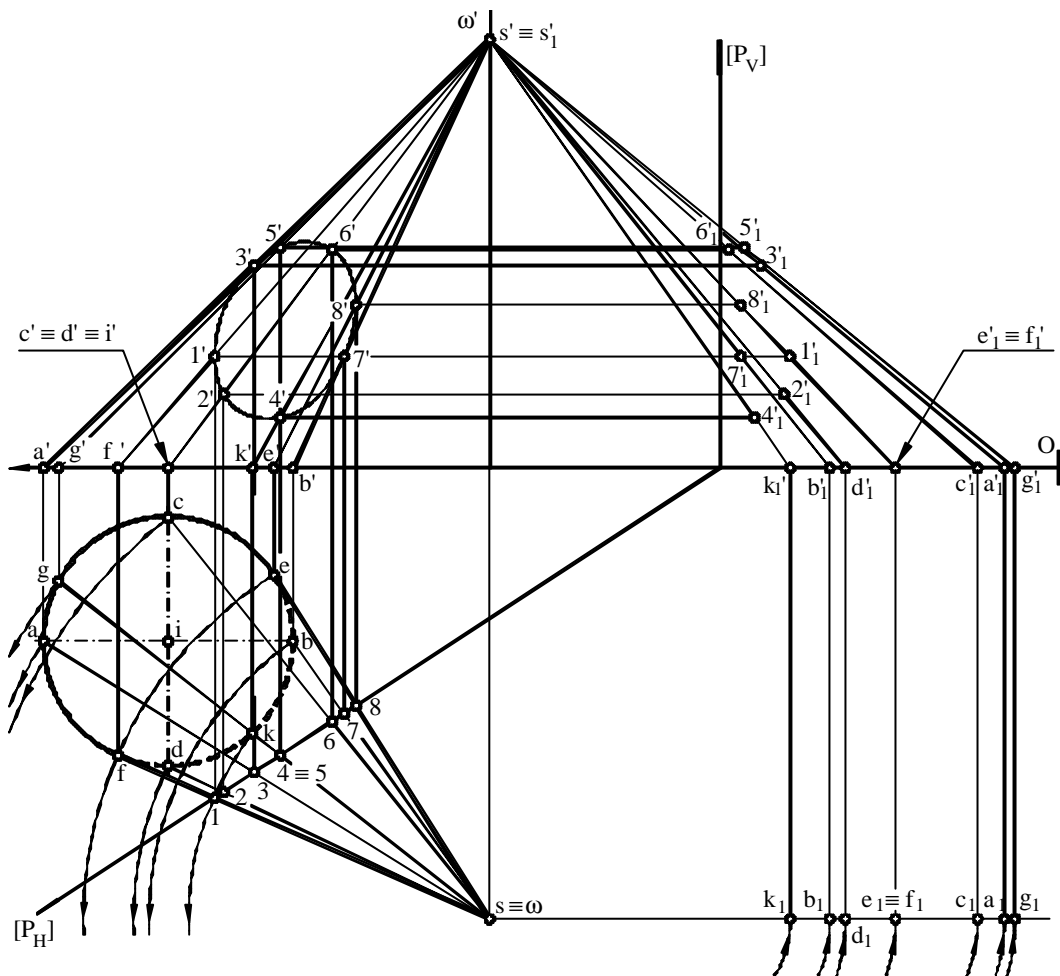

Fig. 3. Development of a cone frustum with unparallel bases -constructive elements

In principle, the cone frustum which resulted by intersecting the given cone with the P vertical plane is done just like in the previous case, following the same constructive stages.

The real size of a sufficient number of generators (they are either any or conveniently chosen) is determined by doing a level rotation, in which the rotation axis is a vertical line which passes through the cone tip.

The intersection between cone and $P(P_H, P_V)$ plane is an ellipse type curve. As the section plane is a projecting plane, the horizontal projections of section curve points are found at the intersection of P_H horizontal trace of $[P]$ with the horizontal projections of generators. The 1, 2, ..., 8 horizontal projections of section curve points are obtained; by order lines the $1', 2', \dots, 8'$ vertical projections are found too.

By rotating the generators, the 1, 2, ..., 8 points also rotated in the $1', 2', \dots, 8'$ positions, which determine segments of cone frustum generators in real size. Further on, the cone development is done (fig. 4), using the same methods like in the previous cases, thus obtaining the A_0, E_0, \dots, A_0 curve line, the development of cone directrix curve.

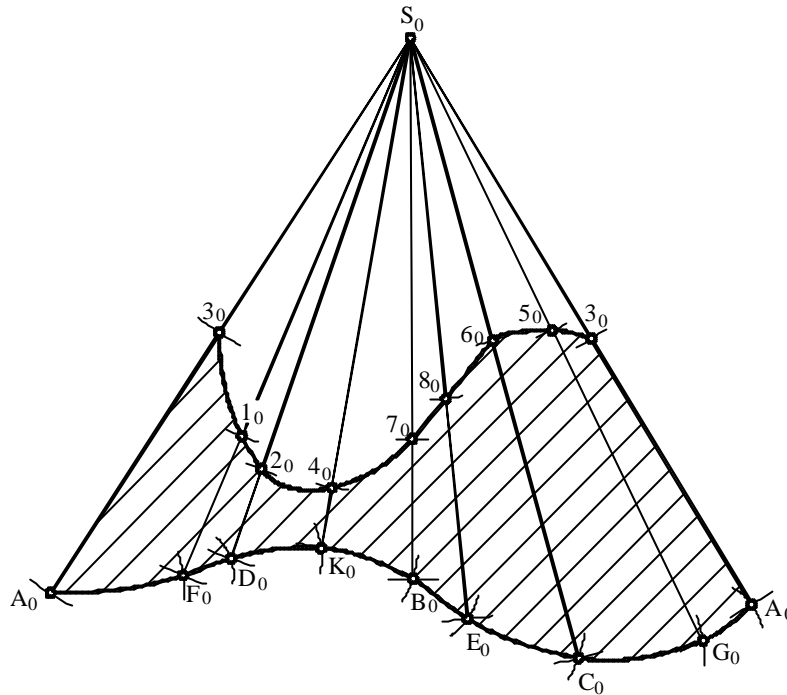

Fig. 4. Surface development of a cone frustum with unparallel bases

Finally, the segments in real size of the distances from tip to the $(s'_1, s'_2, \dots, s'_8)$ section curve are taken and put on the generator transforms on which are found. The $3_0, 1_0, \dots, 5_0, 3_0$ curve line is obtained, and this is the development of section curve.

The construction of the diretrix curve and of the section curve is done with the help of AutoCAD using the same procedure like in chapter 2..

4. Conclusion

The development of conic surfaces given in the examples in the paper was obtained using perspective geometry theoretical notions; their graphical construction was done using modern procedures, by the help of AutoCAD notions and commands.

By AutoCAD procedures of using interpolating polynoms, the current points of the diretrix curve as well as those of the section curve necessary for the construction can be reduced; the development construction is more correct, being approximately identical with the real one.

References

- [1] **Botez St. M.**, *Geometrie descriptiva*, Editura Didactica si Pedagogica, Bucuresti, 1965;
- [2] **Gordon, S.** *Geometrie descriptiva.*, Editura Tehnica, Bucuresti, 1952;
- [3] **Lazar, M., Popa, D.**, *Geometrie descriptiva.*, Editura Tehnica, Bucuresti, 2003 ;
- [4] **Moncea, J.** *Geometrie descriptiva si desen tehnic. - Geometrie descriptiva*, Editura Didactica si Pedagogica, Bucuresti, 1982.
- [5] **Moncea J., s.a.**, *Desfasurarea suprafetelor.* Editura tehnica, Bucuresti, 1975;
- [6] **Popa, D., Popa C.** *Proiectare asistata în ingineria mecanica* , Editura Tehnica, Bucuresti, 2003;