

A STUDY ON THE TRACKING MECHANISMS OF THE PHOTOVOLTAIC MODULES

TATU Irina, ALEXANDRU Cătălin

"Transilvania" University of Braşov, Product Design & Robotics Dept.

nicoleta-irina@unitbv.ro, calex@unitbv.ro

Keywords: solar energy, photovoltaic, array, tracking mechanism.

Abstract: One important problem of today's society is the continuous growing demand of electric energy versus the constant drop of the fossil fuels. The solution is the renewable energy, like Sun, wind and water. The conversion of the solar energy in electric energy is one of the most addressed topics in the field of renewable energy systems. The photovoltaic (PV) conversion can be improved by use of mechatronic systems for the orientation of the PV modules. In this paper, we present the steps taken into consideration when engineering a PV system with tracking. We describe the various types of tracking systems that must be designed according to Sun-Earth position, having in view to maximize the incident solar radiation (normal to the active surface). On the other hand, the PV systems are characterized according to the arrangement of modules, with the emphasis on the array of modules.

1. INTRODUCTION

The photovoltaic systems belong to the renewable energy domain, an area that tries to diminish the problems which arise from the use of fossil energy resources (limitative nature, pollution, global warming) [2]. The PV systems convert the solar energy into electric energy, without the emission of pollutant gasses into the atmosphere. They were first used to supply satellites in space. Nowadays, they have found an application in various domains, from electronic watches to cars. At a greater scale, the PV systems are used to supply with electric energy remote locations or feed the electricity in the grid. Because they are used in a small percentage as electric energy suppliers, continuous research is done in order to improve their yield, simpler design, cost effective and more energetic efficient photovoltaic systems.

The solar energy is the most important renewable energy source, and it offers enormous potential to generate clean, carbon-free power. Its advantages are not only environmental, but also they have a great degree of security and stability, since the problems with fossil fuel supply and nuclear fuel cycles are avoided. Furthermore, the Sun represents a free source of energy, so the solar energy does not have price variability. In this manner it does not influence the economic growth.

The Sun is the biggest star in our solar system, which generates energy through the nuclear reactions that occur in its nucleus. In fact, the Sun is a continuous enormous nuclear reactor with a diameter of 1.39×10^9 m and at a distance of 1.5×10^{11} m from the Earth. The Sun is composed of only gases, with a majority of 71% hydrogen, 27% helium and 2% other gases, mainly oxygen, nitrogen and carbon.

The energy is formed in the centre of the Sun, where there is a temperature of approximately 13.6 MK. Here, hydrogen protons clash and merge to form helium nuclei (four hydrogen protons form one helium nucleus). This fusion reaction with a 0.7% loss of mass converted to energy is the source of the energy in the Sun. The gamma rays representing the energy diffuse so slowly to the surface of the Sun that it takes 1 million light years to reach the surface of the Sun.

The 150 millions km between Sun and Earth are being traveled by the solar radiation with the speed of light (300.000 km/s) reaching the surface of the Earth after 8.3 minutes. Outside the Earth's atmosphere, the solar radiation has an intensity of approximately 1370 W/m^2 , but once it enters the atmosphere the radiation it is reduced due to its scattering, absorption and reflection.

The photovoltaic modules convert the solar energy into electric energy by way of solar cells, e.g. wafer-based crystalline silicon cells, thin-film cell based on cadmium telluride or silicon, etc. [10]. These are protected from damaging elements (rain, hail, etc.) by a sheet of glass on the front side. When the Sun rays hit the module, the photovoltaic effect occurs at the level of solar cell, thus producing electric energy. This buildup of voltage is generated by the electrons transferred from different bands within the material of the solar cell.

The efficiency of the PV systems depends on the degree of use and conversion of the solar radiation. The energy balance refers to the surface that absorbs the incoming radiation and to the balance between energy inflow and energy outflow. The rate of useful energy leaving the absorber is given by the difference between the rate of incident radiation on absorber and the rate of energy loss from the absorber. The degree of use of the solar radiation can be maximized by use of mechanical systems for the orientation of the PV panels in accordance with the paths of the Sun.

2. MODELLING THE SOLAR RADIATION

The global solar radiation (fig. 1) represents the sum of the direct radiation - A (the solar radiation that reaches the Earth's surface without being diffused) and diffuse radiation - B (the Sunlight that passes through the atmosphere is absorbed, scattered and reflected by air molecules, water vapor, clouds, dust, etc.). The diffuse solar radiation is present even in a cloudless day (being almost 10% of the global solar radiation). If the sky is covered in clouds the diffuse radiation is the only one present, the direct solar radiation being equal to zero.

The solar radiation received at the Earth's surface is influenced by various factors, specific for each area, such as: geographical coordinates, relief configuration, season, hour, climatological conditions and parameters (clouds, rain, atmosphere's turbidity,) and degree of pollution. In order to estimate the solar radiation in any region, in which a system for converting the solar energy into electricity is going to be implemented, there are used various experimental methods, as meteorological database (ex. Meteonorm) or empiric methods, as mathematical models. (ex. Kasten model, Adnot model and Haurwitz model for global radiation, Bugler model - for diffused radiation, Hottel model - for direct radiation).

These models are very used because of their simplicity (they have as input parameters only the location and time marks, the main one being the solar altitude angle), but, because they are derived methods from measurements (i.e. empirical methods), they are specific to a certain geographic location. The maximum value of the solar radiation is obtained for the solar noon (at which the maximum value of the altitude angle is corresponding). Because the altitude angle gives a symmetrical radiation function, the theoretic radiation values towards sunset and sunrise are equal; fact not true in real conditions, due to the possibility of variable meteorological conditions [7].

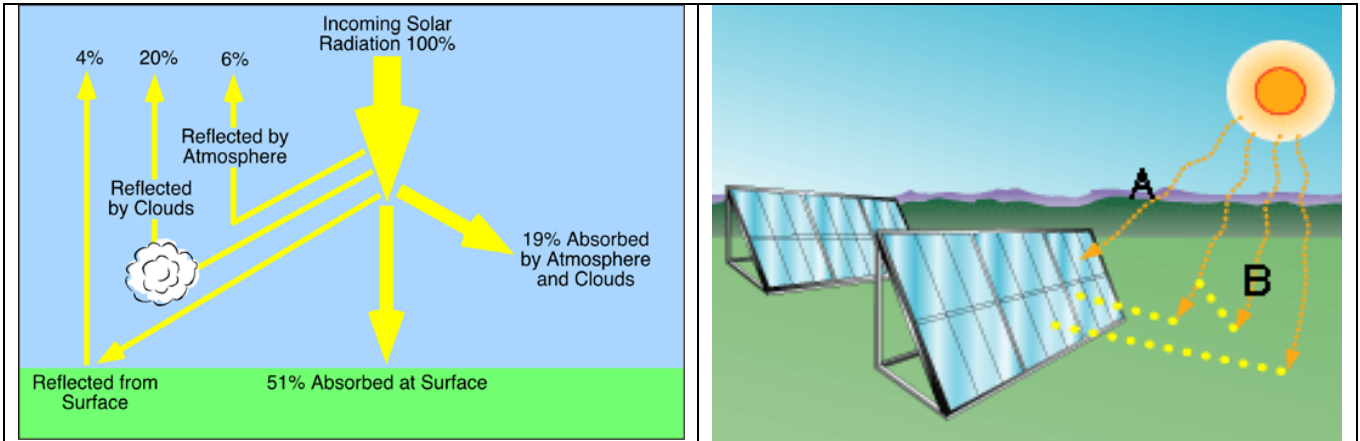

Figure 1. The distribution of global solar radiation [17].

A main influence factor on the solar radiation is the turbidity factor representing the sky clarity level or the amount aerosol in the atmosphere that has an influence on the direct radiation received at the Earth's surface. There are several atmospheric turbidity factors found in the literature, like: Linke turbidity factor, Unsworth-Monteith turbidity factor, Ångström turbidity parameters etc. Of all, Linke turbidity factor is the most commonly used. It is very important to determine this turbidity factor as it is an input parameter to models computing the solar radiation under clear sky. Another fact that contributes to its importance is the particularity of different geographical areas. If it is calculated when there are clouds covering the sun, it will show more the intensity and position variability of clouds than the actual value of the atmosphere's turbidity. So, the days with cloudy sky have to be removed during the study.

In Braşov, the turbidity factor was noticed to have a two cycle variation: from October (in this month being recorded the smallest values) to March is low and from April to September it has high values. The highest values were recorded in June and August. The daily minimum value is recorded at sunset, the turbidity factor having a daily variation depending on the solar time. These values and observations were recorded using two models: Kasten-Young model and Remund-Page [8].

3. ABOUT THE SOLAR TRACKERS

For the photovoltaic modules to capture as much solar radiation as possible it is necessary that the Sun rays must always fall normal to the modules' plane. To achieve this, solar tracking systems can be used, which continuously change the position of the PV module to keep the desired relations between the Sun rays and the receiver. Basically, the solar trackers are mechatronic systems that integrate mechanics, electronics, and information technology. These mechanisms are driven by rotary motors or linear actuators, which are controlled in order to ensure the optimal positioning of the PV module relatively to the Sun position on the sky dome. The orientation of the photovoltaic modules may increase the efficiency of the conversion system from 20% up to 50% [1, 4, 9, 10, 12, 13, 17].

The following angular parameters give the relations between the Sun and the module, relations which determine the orientation of the PV systems (fig. 2):

- hour angle ω – the angle between the line that connects the Sun and Earth centers and the line that connects the Sun and Earth centers at solar noon, in equatorial plane ;
- altitudinal angle α – the angle between the horizontal plane and Sun ray;
- solar zenith angle θ – the angle between the normal on module and the line that connects the Sun's centre and the location of the module;

- solar azimuth angle ψ – the angle between the projection of the Sun ray and a line orientated from North to South, in the horizontal plane of the location;
- solar declination δ – the angle between the axis of the Earth-Sun centers (Sun ray) and the Earth's equatorial plane.

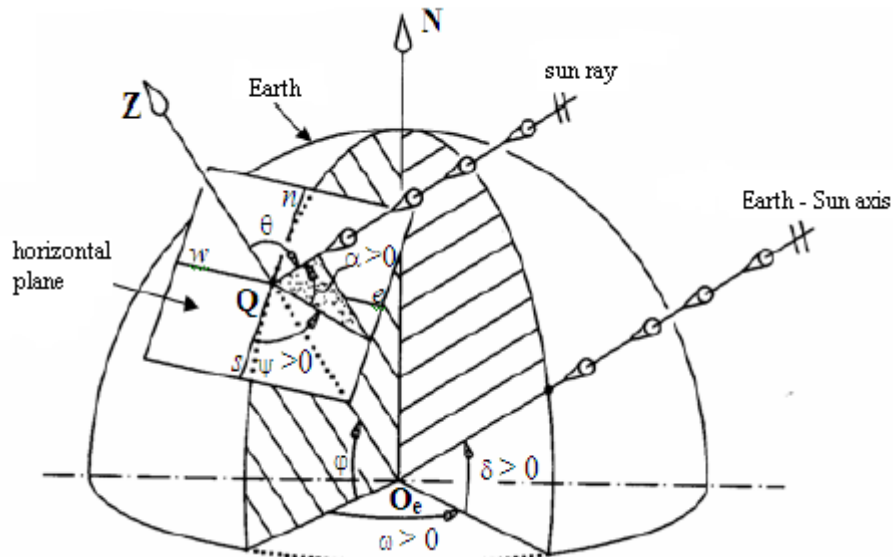

Figure 2. The Earth – Sun angle in the global (equatorial) system

Based on the two axes of Earth's motion, the orientation systems can be: one-axis and dual-axis. The first systems follow only the daily rotation, so its rotation axis must be adjusted each season. They have the advantage of low cost, due to fewer elements and only one motor source, but the yield is smaller than the one of dual-axis systems. The last do not require adjustments, so they benefit of a very precise orientation. They can be further divided, according to the sequence of rotations, into the following (fig. 3): equatorial, pseudo-equatorial, and azimuthal.

For the equatorial tracking systems, there are two independent motions, because the daily motion is made rotating the PV panel around the fixed polar axis. Their motions sequence generates constructive problems, so these systems are usually avoided.

The pseudo-equatorial tracking system is derived from the polar one, by reversing the rotations order (thus, the fixed axis is for the elevation motion); in this way diurnal adjustment of the elevation angle is necessary (and not just seasonal) to ensure the optimal positioning of the daily motion axis. This reversion makes the systems more stable, thus more used.

For the azimuthal trackers, the main motion is made by rotating the PV panel around the vertical axis, so that it is necessary to continuously combine the vertical rotation with an elevation motion around the horizontal axis. These systems have the advantage of a good accuracy of modules' positioning compared with the Sun and enhanced structural stability. An important disadvantage is that the two motions are interdependent (compared with equatorial and pseudo-equatorial – independent motions) so their drive has to be simultaneous.

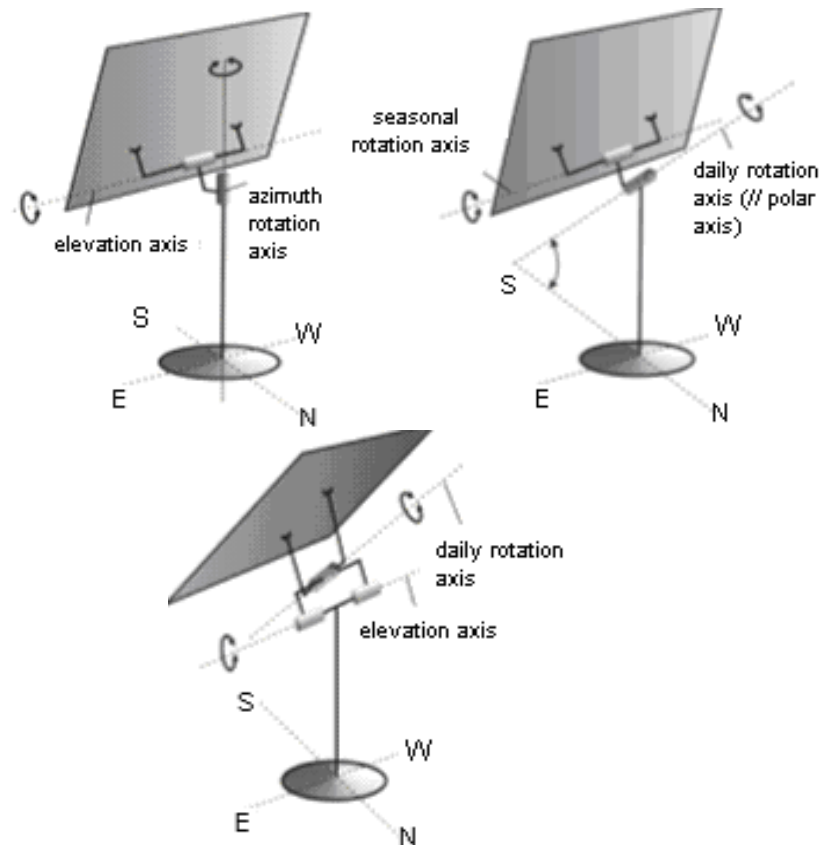

Figure 3. Basic types of tracking systems: a) azimuthal; b) pseudo-equatorial; c) equatorial.

As was mentioned, the tracking systems contain mechanisms which are driven by controlled rotary motors and/or linear actuators (generally, electrically operated). Concerning the control process, closed loop systems with photo sensors are traditionally used. The photo sensors are responsible for discrimination of the Sun position and for sending electrical signals, proportional with the error, to the controller, which actuates the motors to track the Sun. Nevertheless, the orientation based on the Sun detecting sensors may introduce errors in detection of real sun position for variable weather conditions.

The alternative consists in opened loop systems, which are based on mathematic algorithms/programs that may provide predefined parameters for the motors, depending on the sun positions on the sky dome (i.e. the astronomic movements of the Sun - Earth system). These positions can be precisely determined because they are functions of the solar angles that can be calculated for any local area. By using this control technique, based on predefined parameters, the errors introduced by the use of the sensors may be avoided.

Another solution is to incorporate some kind of Sun position sensor to check and calibrate the astronomical control system automatically. In addition, the tracking system can also be adjusted to provide maximum output energy, to self-trim it initially or self correct itself throughout its life. Such hybrid control systems consist of a combination of opened loop tracking strategies, based on solar movement models and closed loop strategies, using dynamic feedback controller.



Figure 4. Tracking systems designed and implemented at Transilvania University of Braşov:
a) pseudo-equatorial [3], b) azimuthal [15], c) pseudo-equatorial platform [5]
b)

4. PV ARRAYS

The realization of the photovoltaic arrays appeared as a necessity for the development of large systems for producing electric energy based-on the solar energy. A PV array is a linked collection of photovoltaic modules, which are in turn made of multiple interconnected solar cells. In practice there are two solutions for developing the PV arrays with tracking:

- I. individual PV modules, where the modules are separately mounted on individual sustaining structures;
- II. PV platforms, where the modules are mounted on a common frame (modules with same sustaining structure), orientation being realized simultaneously by the orientation of the entire platform;

The PV platforms, even if they have the advantage of a unitary electrical scheme, generate multiple inconvenient concerning the construction, which has to be solid, or integration in the built environment, which may be difficult or even impossible (for example, it cannot be mounted on a roof because these impose the construction of a foundation). Another disadvantage of the platforms consists in the fact that the efficiency of the system may be smaller because of the close mounting of the panels that may provoke overheating.

The array with individual modules eliminates the disadvantages of the platforms but they need a larger area for mounting (the sustaining structure is not compact as in the case of the platforms), and the disposer of them have to care out of the eventual auto shadings. In this case, the orientation can be realized in two ways:

- I.1. tracking independently each module of the group (module with own orientation system - self motor sources);
- I.2. simultaneous tracking of all modules of the group (fig. 5) by using single driving source (for one-axis tracking systems) or two driving sources (for dual-axis tracking systems), and mechanisms for transmitting the motion to all modules of the group; for the dual-axis systems there can be developed mechanisms that allow to use a single motor for both motions (this solution is viable for the pseudo-polar and azimuthal systems, where both motions are executed every day).

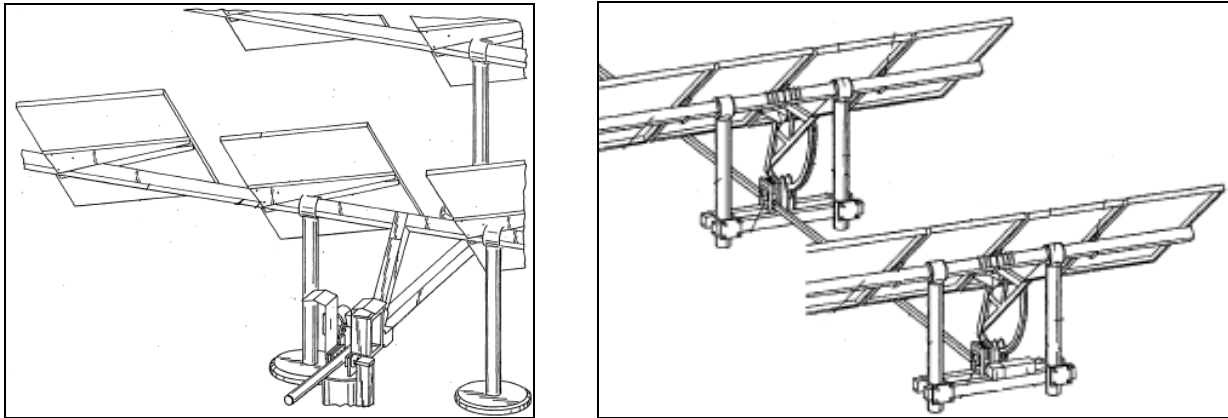

Figure 5. Examples of patented PV array mechanisms: a) rows driving mechanism of a solar tracker [6]; b) single axis solar tracker mechanism [16]

Obviously, the second solution (1.2) even if it is more complex by constructive aspects (needs the design of the mechanisms suitable for transmission of the power from the driving source to the modules of the group) it ensures theoretically a greater energetic and economic efficiency because of the minimization of the motor sources in the group (the controlled motor being the most expensive component of a photovoltaic tracking system). The simultaneous orientation of the group of modules, with the predicted advantages and the characteristic problems that involves, opens a research area insufficiently explored since now, fact sustained by the literature and practical developments in the field that refer almost entirely to the orientation individual modules.

A specific problem for the photovoltaic groups consists in the establishing of the disposing mode of the modules. Basically, the modules can be arranged in line, in string, or in matrix, the number of modules in a specific emplacement scheme depending on the energy requirement, as well as the available area. For dimensioning the group depending on the available modules (defined by the active surface, the rated power, the conversion efficiency, the short-circuit current, the system voltage), different programs (e.g. KACO, VALENTIN PV-SOL) or on-line calculators can be used. At the same time, knowing the losses due to self-shading among modules is a key issue, because it allows optimizing the placement of the modules over the area as well as quantifying the energy production losses. For calculating the irradiance losses due to self-shading among trackers as a function of the position and distance among them, the "butterfly" graphics (fig. 6) with the percentage of shading losses are frequently used [14].

The PV arrays with tracking mechanism can be designed with different number of motor sources, usually two motors for the bi-axis tracking systems, or one if they are mono-axis. At the same time, there can be tracking systems with one motor source and two rotational axes; this mechanism reduces the overall cost of the system, by minimizing the number of motors.

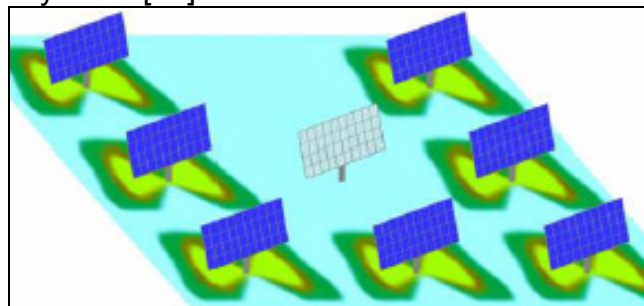

Figure 6. The butterfly graphic for avoiding self-shading

Usually, the modules in a PV array are first connected in series to obtain the voltage required, and then, these strings are connected in parallel to increase the resulting direct current, which is transformed into alternative current through an inverter. In remote or

mountainous areas, PV arrays are used to generate electricity as stand-alone systems. A more practical application is feeding the grid because this leads to optimum use of the investment in the PV system. Because solar electricity is not available at night or in cloudy weather conditions, a storage power system is used, usually a battery or an accumulator (also used in remote areas due to the excess electricity).

In these conditions, the future research will consider the simultaneous orientation of a PV array, with one or two driving sources, implemented in the geographical area Braşov. The control strategies will be based on algorithms depending on the sun positions on the sky, as well as predictive tracking strategies based on meteorological prognoses.

ACKNOWLEDGEMENTS

This paper is supported by the Sectoral Operational Programme Human Resources Development (SOP HRD), ID59321 financed from the European Social Fund and by the Romanian Government.

REFERENCES

- [1] C. Alexandru, The Mechatronic Model of a Photovoltaic Tracking System. International Review on Modelling and Simulations, Vol. 0 (0), 2008, p. 64-74.
- [2] I. Bostan, V. Dulgheru, I.Sobor, V. Bostan, A. Sochireanu, Sisteme de conversie a energiilor regenerabile, Ed. Tehnica-Info, Chişinău, 2007.
- [3] B. Burduhos, Optimizarea Mecanismelor de Orientare de Tip Pseudo-ecuatorial Utilizate pentru Creşterea Eficienţei Conversiei Panourilor Fotovoltaice Individuale, Ed. Universităţii Transilvania, Braşov, 2009.
- [4] K.K. Chong et al. Integration of an On-Axis General Sun-Tracking Formula in the Algorithm of an Open-Loop Sun-Tracking System. Sensors, Vol. 9, 2009, p. 7849-7865.
- [5] M. Comşiţ, Mecanisme de Orientare Specifice Sistemelor de Conversie a Energiei Solare , Ed. Universităţii Transilvania, Braşov, 2007.
- [6] R. Corio, Single Axis Solar Tracking System, US 2008/0308091, US, 2008.
- [7] L.Coste, E.Eftimie, Computer Programs for Climatological Parameters Calculation and Radiation Simulation, Bulletin of the Transilvania University of Brasov, 2009, Vol. 2(51), p. 33-40.
- [8] E. Eftimie, Beam Horizontal Irradiance Simulation for Brasov Urban Area - Clear Sky, Proceedings of the 2nd WSEAS International Conference on Environmental and Geological Science and Engineering - EG'09, Brasov, 2009, p. 224-229.
- [9] L. Guo et al. Design and Implementation of a Sun Tracking Solar Power System. Proceedings of the ASEE Annual Conference and Exposition, Austin, 2009, p. 1-11.
- [10] A. Hoffmann et al. A Systematic Study on Potentials of PV Tracking Modes. Proceedings of the 23rd European Photovoltaic Solar Energy Conference - EUPVSEC, Valencia, 2008, p. 3378-3383.
- [11] T. Markat, L. Castañer, Photovoltaics: Fundamentals and applications, Ed. Elsevier, Amsterdam, 2006.
- [12] H. Mousazadeh et al., A Review of Principle and Sun-Tracking Methods for Maximizing Solar Systems Output. Renewable and Sustainable Energy Reviews, Vol. 13, 2009, p. 1800-1818.
- [13] L. Narvarte, E. Lorenzo, Tracking Gains and Ground Cover Ratio, Proceedings of the 22nd EUPVSEC European Photovoltaic Solar Energy Conference, Milan, 2007, p. 3153-3156.
- [14] P.J. Perez, G. Almonacid, P.G. Vidal, Estimation of Shading Losses in Multi-Trackers PV Systems, 22nd European Photovoltaic Solar Energy Conference, European Commission & WIP Renewable Energies, Milano, 2007, p. 2295-2298.
- [15] V. Popa, Creşterea Eficienţei Energetice a Panourilor Fotovoltaice prin Mecanisme de Orientare de Tip Azimutal, Ed. Universităţii Transilvania, Braşov, 2009.
- [16] J. Shingleton, Tracking solar collector assembly, WO 2004/083741, US, 2004.
- [17] I. Vişa, D. Diaconescu, V. Popa, On the Optimization of the PV Azimuthal Tracking Steps. Proceedings of the 23rd European Photovoltaic Conference EUPVSEC, Valencia, 2008, p. 3165-3169.
- [18] <http://www.physicalgeography.net/fundamentals/images/cascade.GIF> found at the date 11.03.2010.