

## **BIOMECHANICAL BEHAVIOUR OF IMPLANTED LONG BONES**

**TOTH-TASCAU Mirela\*, RUSU Lucian\*, TOADER Cristian\***

\* Politehnica University of Timișoara, Faculty of Mechanical Engineering, Bd. Mihai  
Viteazu No 1, 300222 Timișoara

[mirela@cmpicsu.upt.ro](mailto:mirela@cmpicsu.upt.ro), [luck@cmpicsu.upt.ro](mailto:luck@cmpicsu.upt.ro), [cristian.pasti@yahoo.com](mailto:cristian.pasti@yahoo.com)

**Keywords:** long bone, implant, numerical analysis, 3D modeling, biocompatible material

**Abstract:** Many studies concerning the mechanical behaviour of surgical implants were developed in the frame of the Multiple Users Research Centre - *Centre for Modelling Prosthetic Devices and Surgical Interventions on Human Skeleton* in order to offer to the potential users the optimal solution in the case of accidental or congenital damages of the human skeleton bones. The paper is analysing the biomechanical characteristics of surgical implants used to fix the long bones fractures. Implanting of one or two external mini-plates, having different shapes, fixed by small screws was analyzed. Biomechanical behaviour was studied based on numerical analysis by Finite Element Method.

### **1. INTRODUCTION**

In the frame of the Multiple Users Research *Centre for Modeling Prosthetic Devices and Surgical Interventions on Human Skeleton* in POLITEHNICA University of Timisoara, a set of implant plates made in Titanium alloy were designed and manufactured. These implants can be used both for repairing the head skeleton fractures, and to fix the long bones fractures.

The long bones have a composite structure consisting of cortical bone and marrow core, so is different in the transverse and longitudinal directions, and it performs different mechanical properties while is loaded along different directions. The literature is rich in observations [3], [5], [6] about the variation of the mechanical properties. If an accidental damage occurs, it is also important to know what it will be produced in the regions characterized by a decreased mineral content where the bone is most trabecular and the mechanical properties are at low level. So, the choice of the material and shape of implant devices will depend on: bone properties, place of damage, quantity of bone fragments, access to the fracture place, etc.

Because of the very large materials field used for implants and prosthetic internal devices, it is necessary to consider those accomplishing the highest level of bone functional necessity. Generally, biocompatible stainless steel and titanium alloys are used.

The aim of this paper is to present some results of numerical analysis of long bones implanted with plates having different shapes and fixed with different number of screws. The stress distribution and deformation diagram in an implanted piece of bone were obtained, taking into account two titanium alloy implantation plates and screws.

### **2. NUMERICAL ANALYSIS**

One of the most recommended fixation plate, designated to repair the bone fractures, has the shape presented in Figure 1, whose fixation can be achieved using 2 to 5 screws. The implant plate is fixed in different points by Titanium screws. The stress distribution, as well as the deformation, depends on the fixation style.

The shape of the plate is appropriate for linear, as well as comminuted fractures, because the two upper branches and the middle plate can fix together many bone fragments. The raw metal sheet (0.8 mm in thickness), used to produce the surgical implant, is made of Titanium biocompatible alloy VT1 (Table 1).

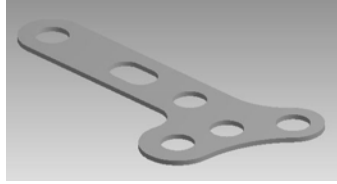

**Figure 1. Implant plate**

**Table 1. Chemical composition of the VT1 Titanium alloy (%)**

<b>N</b>	<b>C</b>	<b>H</b>	<b>Fe</b>	<b>O</b>	<b>Al</b>	<b>V</b>	<b>Mo</b>	<b>Zr</b>	<b>Si</b>	<b>Ti</b>	<b>Σres</b>
0.03	0.05	0.003	0.12	0.11	0.48	-	-	-	0.05	base	0.25

The material structure presents uniform grains without non-metallic inclusions. The implants were produced by unconventional technologies. The physical and mechanical characteristics of the metal and bone materials, important for the FE analysis, are presented in Table 2.

**Table 2. Physical and mechanical characteristics of metal and bone**

<b>Mechanical characteristics</b>	<b>Implant (VT1)</b>	<b>Bone cortical</b>	<b>Bone marrow</b>
Young modulus	96.000,0 MPa	8.000,0 MPa	1.100,0 MPa
Poisson' coefficient	0.36	0.3	0.42
Density	$4.62 \times 10^{-6}$ kg/mm <sup>3</sup>	$3.0 \times 10^{-4}$ kg/mm <sup>3</sup>	$9.5 \times 10^{-7}$ kg/mm <sup>3</sup>
Tensile yield stress	930.0 MPa	100.0 MPa	25.0 MPa
Tensile ultimate stress	1070.0 MPa	135.0 MPa	33.0 MPa
Compressive yield stress	930.0 MPa	40.0 MPa	0.0 MPa
Compressive ultimate stress	0.0 MPa	67.0 MPa	0.0 MPa

The numerical analysis was realized using ANSYS DesignSpace 7.0 on a fractured femur central zone [2], [7]. The fracture appeared as result of the external shock due to an accident and the bone was implanted using the plate presented in Figure 1 and 4 screws. Meshing of the implant-bone system is presented in Figure 2 and loading of the implant-bone system is presented in Figure 3 [1], [4].

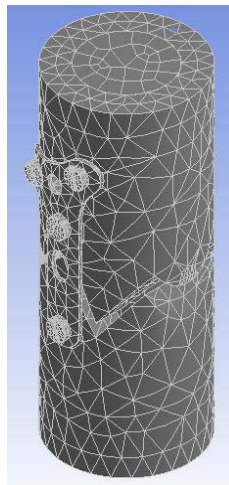

**Figure 2. Meshing of implant-bone system**

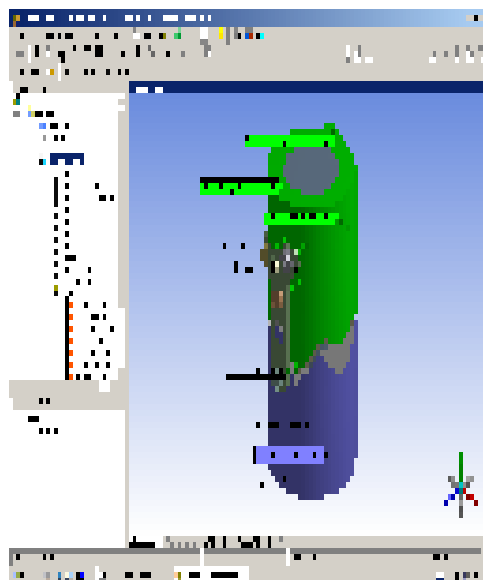

**Figure 3. Loading of implant-bone system**

The numerical analysis was performed on the mentioned implant with contact conditions type set on *Bounded* [2]. The system loadings were in all cases the same: a grip force along every screw axis (10N), a force of 100 N along the bone axis distributed on the transverse bone surface, a torsion moment (50 N·mm) applied to the upper fragment of the fractured bone and a bending force (100 N) normal to the long edge of the implant (Figure 3). The lower extremity of the bone is fixed in a cylindrical support and the marrow is rigidly bounded to the bone. The meshing characteristics are presented in Table 3.

**Table 3. Meshing characteristics for implanted long bone**

Name	Material	Bounding box Dimensions [mm]	Mass [kg]	Nodes	Elements
Bone fragment 1	Bone	40.0; 58.4; 40.0	1.07	4880	2774
Bone fragment 2	Bone	40.0; 56.5; 40.0	1.10	3572	1942
Bone core	Marrow	25.0; 100.0; 25.0	$4.66 \times 10^{-3}$	3108	630
Plate	Titanium alloy	26.2; 53.1; 9.8	$2.48 \times 10^{-3}$	1017	422
Screws 1, 2, 3, 4	Titanium alloy	8.0; 8.0; 7.0	$5.37 \times 10^{-3}$	1235	669

In figures 4 to 7 are presented the results of the FE analysis for the bone implanted with the plate presented in Figure 1 and 4 screws.

The results of the FEM analysis are presented in the Table 4 for all studied cases (fixation with 2 to 5 screws). It can be observed that the stresses are always lower than the limits indicated in Table 2 for implant, bone or marrow. It means a good mechanical behavior of the implanted system.

It is obvious that the stress values are generally higher than the limits indicated in Table 2. But, because the implant plate placed on a long bone is submitted to compression, the comparison is interesting for these values. Thus, in Table 4 the compression stress is under the limit of 930 MPa, the minimum compressive stress being 594.2 MPa in the case of 4 screws fixation. It must also be mentioned that the external loading was significantly lower than the case when, for example, the implanted bone is a femur and the force along the bone axis is normally into the interval 300 – 500 N, as function of the patient own weight.

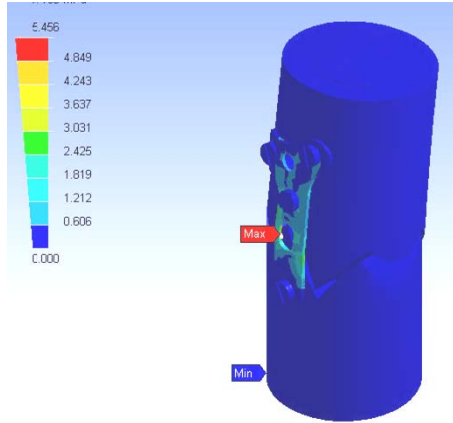

**Figure 4. Global stress distribution**

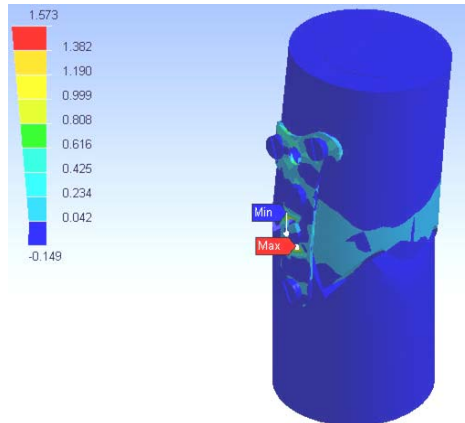

**Figure 5. Global maximum principal stress**

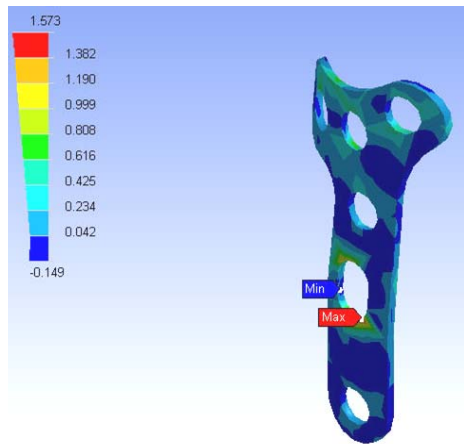

**Figure 6. Implant principal stress**

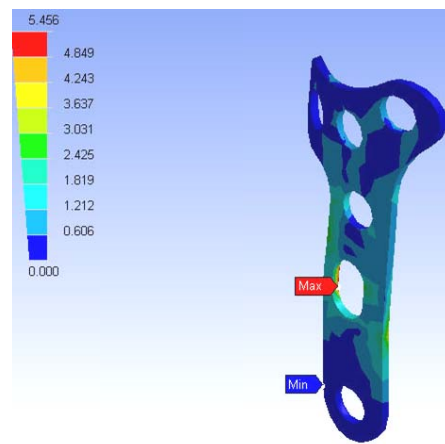
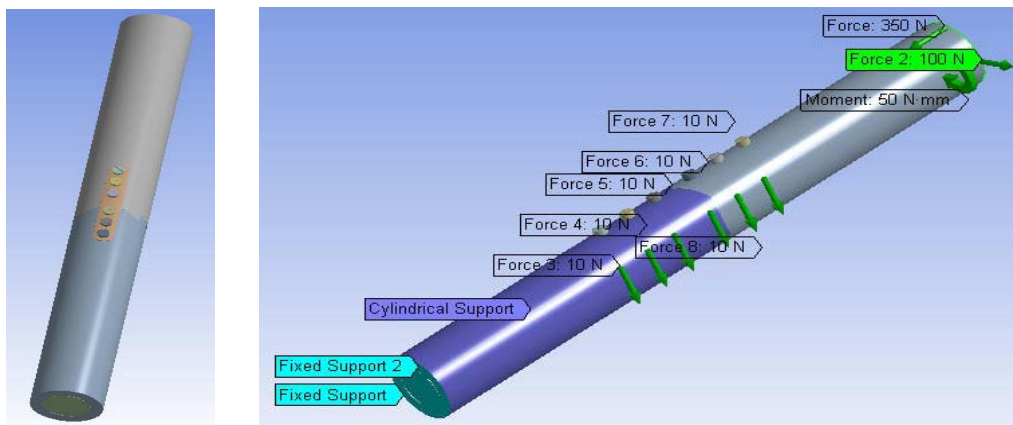

**Figure 7. Implant stress intensity**

**Table 4. FE analysis results for implanted long bone**

Stress and deformation	Number of fixations			
	2	3	4	5
Maximum equivalent stress [MPa]	5626.4	5200.8	5316.3	5900
Minimum equivalent stress [MPa]	0.0170	0.0152	0.0149	0.0157
Maximum normal stress [MPa]	1348.9	1428.5	1454.8	1735.4
Minimum normal stress [MPa]	-685.6	-765.2	-594.2	-890
Maximum shear stress [MPa]	475.2	532.1	607.2	762.5
Minimum shear stress [MPa]	-500.4	-510	-690.1	-1002
Tensile yield stress [MPa]	930.0			
Maximum total deformation [mm]	1.50	4.90	5.35	3.89
Maximum directional deformation Ox [mm]	0.36	0.77	0.85	0.75
Maximum directional deformation Oy [mm]	0.014	0.018	0.03	0.038
Maximum directional deformation Oz [mm]	0.75	0.56	0.62	0.465

In order to avoid the possibility of braking the implant itself, the plate shape was simplified (Figure 8) and tested under the action of an augmented axial force as it was mentioned before. The plate is always symmetrically fixed with 2, 4 and 6 screws, the results of the FEM analysis being presented in Table 5.



**Figure 8. Simplified implant shape and its loading**

**Table 5. FE analysis results for implanted long bone with simplified implant plate**

Stress and deformation	Number of fixations		
	2	4	6
Maximum equivalent stress [MPa]	1912	1909	1650
Minimum equivalent stress [MPa]	$7.17 \times 10^{-5}$	$7.23 \times 10^{-5}$	$7.24 \times 10^{-5}$
Maximum normal stress [MPa]	873	886	401
Minimum normal stress [MPa]	-459	-687	-799
Maximum shear stress [MPa]	347	351	374
Minimum shear stress [MPa]	-436	-435	-315
Tensile yield stress [MPa]	930.0		
Maximum total deformation [mm]	0.23	0.23	0.23
Maximum directional deformation Ox [mm]	0.22	0.22	0.22
Maximum directional deformation Oy [mm]	0.03	0.03	0.03
Maximum directional deformation Oz [mm]	0.00105	0.00091	0.00079

By comparing the data in Tables 4 and 5 it results a more favorable behavior of the second plate model.

The same plate was analyzed in the case of two identical ones on the opposite sides of the bone (Figure 9). The results are much more favorable and this situation could be considered in surgery as a possible solution to fix a long bone fracture.

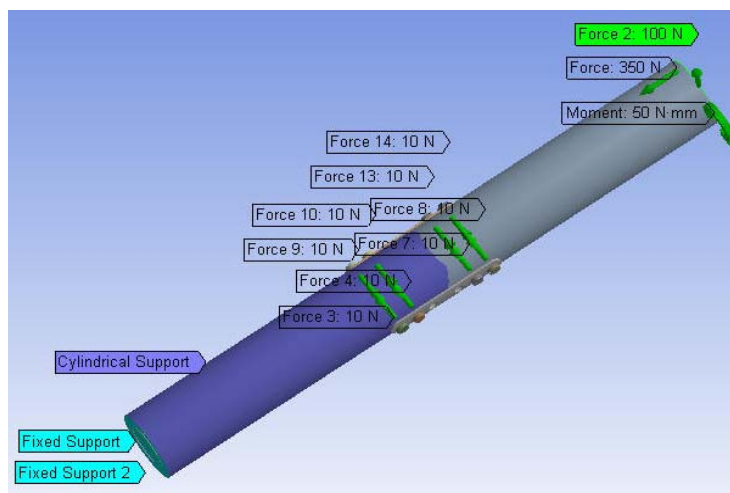

**Figure 9. Placing two implants to fix the long bone fracture**

### **3. CONCLUSIONS**

The paper underlines the possibility to use the same plate implant in Titanium alloy to repair different types of fracture. In the case of the long bones fractures, the same plate can be useful if, after the implantation, the bone will be immobilized during rehabilitation and so, the external loading will not act directly on the implanted zone. The use of the implant plates to fix the long bone fracture is favorable because the surgical intervention is not so invasive like in the case of an internal rod fixation.

Concerning the long bones implants, the same implant plate can be used with 4 fixations as the best solution, but in any cases the modification of the implant plate shape will offer better results.

### **4. REFERENCES**

- [1] Angelides. M., et al., Interface Stress Analysis of Implant Fixation Systems, *Computational Methods in Bioengineering*, BED, Vol. 9, pp. 223-234, 1988.
- [2] Carter D.R., Hayes W.C.: Bone compressive strength: the influence of density and strain rate, *Science*, Vol. 194, no. 4270, pp. 1174 – 1176, 1976.
- [3] Carter D.R., Spengler D.M.: Mechanical properties and composition of cortical bone, *Clinical Orthopedics*, Vol. 135, pp.192-217, 1978.
- [4] Chael E.J., et al., Role of Loads and Prosthesis Material Properties on the Mechanics of the Proximal Femur After Total Hip Arthroplasty, *Journal of Orthopaedic Research*, Vol. 10, pp. 405-422, 1991.
- [5] Evans F.G.: *Mechanical properties of bone*, Charles CThomas Publisher, Illinois, USA, 1973.
- [6] Timoshenko S., Gere J., *Mechanics of Materials*, Chapman & Hall, London, UK, 1991.
- [7] Viceconti M., Bellingeri L., Cristofolini L., Toni A.: A comparative study on different methods of automatic mesh generation of human femurs“, *Medical Engineering & Physics*, Vol.20, pp.1–10, 1998.