

EXAMPLES OF FLEXIBLE MANUFACTURING SYSTEMS FOR MILLING MACHINES WITH HORIZONTAL AXIS

CSOKMAI Lehel Szabolcs, GANEA Macedon
University Of Oradea
lcsokmai@uoradea.ro

Keyword: flexible manufacturing. Flexible cells, production, systems

Abstract: A flexible manufacturing system (FMS) is a manufacturing system in which there is some amount of flexibility that allows the system to react in the case of changes, whether predicted or unpredicted. The main advantages of an FMS is its high flexibility in managing manufacturing resources like time and effort in order to manufacture a new product.

A flexible manufacturing system (FMS) is a manufacturing system in which there is some amount of flexibility that allows the system to react in the case of changes, whether predicted or unpredicted. This flexibility is generally considered to fall into two categories, which both contain numerous subcategories.

The first category, machine flexibility, covers the system's ability to be changed to produce new product types, and ability to change the order of operations executed on a part. The second category is called routing flexibility, which consists of the ability to use multiple machines to perform the same operation on a part, as well as the system's ability to absorb large-scale changes, such as in volume, capacity, or capability.

Most FMS systems comprise of three main systems. The work machines which are often automated CNC machines are connected by a material handling system to optimize parts flow and the central control computer which controls material movements and machine flow.

The main advantages of an FMS is its high flexibility in managing manufacturing resources like time and effort in order to manufacture a new product.

Faster, Lower- cost/unit, Greater labor productivity, Greater machine efficiency, Improved quality, Increased system reliability, Reduced parts inventories, Adaptability to CAD/CAM operations

The main disadvantage is its implementation costs.[1]

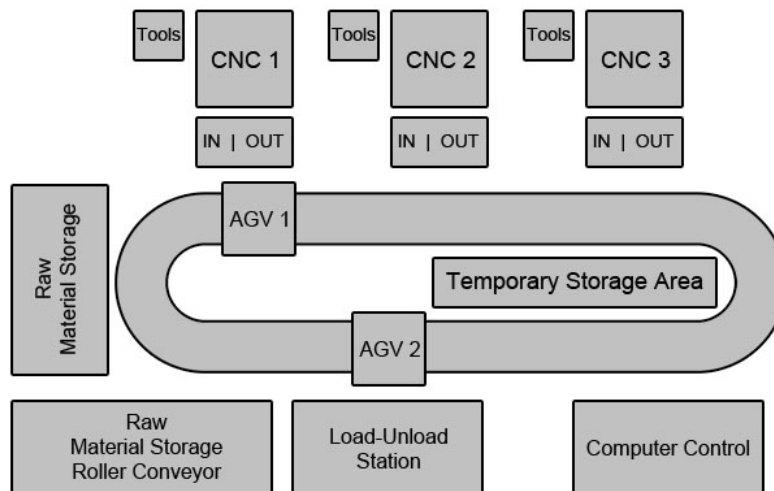

Fig. 1 Flexible manufacturing system.

The basic components of FMS are:

1. Workstations
2. Automated Material Handling and Storage system.
3. Computer Control System

1. Workstations: In present day application these workstations are typically computer numerical control (CNC) machine tools that perform machining operation on families of parts. Flexible manufacturing systems are being designed with other type of processing equipments including inspection stations, assembly works and sheet metal presses. The various workstations are:

- (i) Machining centers
- (ii) Load and unload stations
- (iii) Assembly work stations
- (iv) Inspection stations
- (v) Forging stations
- (vi) Sheet metal processing, etc.

2. Automated Material Handling and Storage system: The various automated material handling systems are used to transport work parts and subassembly parts between the processing stations, sometimes incorporating storage into function.

The various functions of automated material handling and storage system are

- (i) Random and independent movement of work parts between workstations
- (ii) Handling of a variety of work part configurations
- (iii) Temporary storage
- (iv) Convenient access for loading and unloading of work parts
- (v) Compatible with computer control

3. Computer Control System: It is used to coordinate the activities of the processing stations and

the material handling system in the FMS. The various functions of computer control system are:

- (i) Control of each work station
- (ii) Distribution of control instruction to work station
- (iii) Production control
- (iv) Traffic control
- (v) Shuttle control
- (vi) Work handling system and monitoring
- (vii) System performance monitoring and reporting

The FMS is most suited for the mid variety, mid value production range.

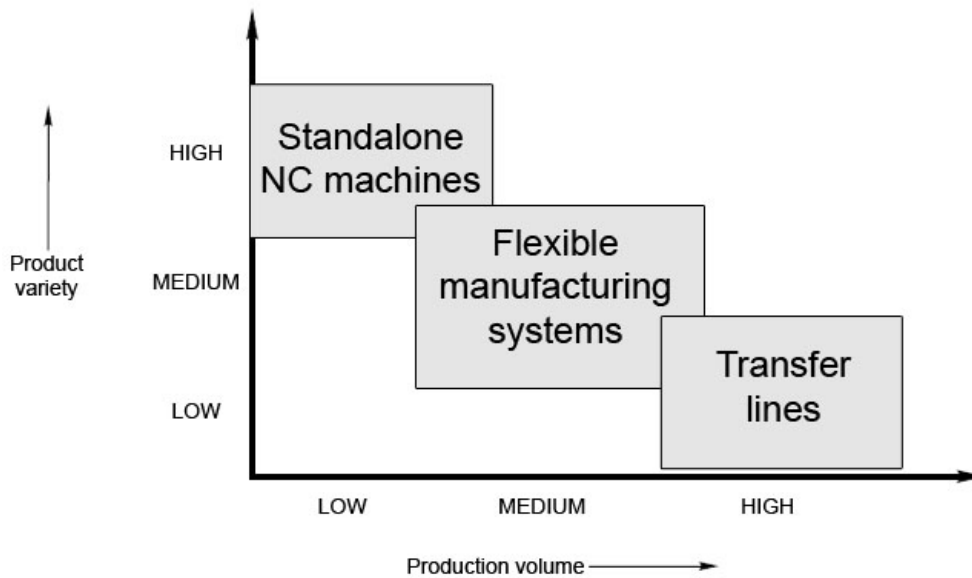

Fig. 2 Application characteristics of FMS

There are three levels of manufacturing flexibility.

(a) Basic flexibilities

- Machine flexibility: The ease with which a machine can process various operations
- Material handling flexibility: A measure of the ease with which different part types can be transported and properly positioned at the various machine tools in a system
- Operation flexibility: A measure of the ease with which alternative operation sequences can be used for processing a part type

(b) System flexibilities

- Volume flexibility: A measure of a system's capability to be operated profitably at different volumes of the existing part types
- Expansion flexibility: The ability to build a system and expand it incrementally
- Routing flexibility: A measure of the alternative paths that a part can effectively follow through a system for a given process plan
- Process flexibility: A measure of the volume of the set of part types that a system can produce without incurring any setup
- Product flexibility: The volume of the set of part types that can be manufactured in a system with minor setup

(c) Aggregate flexibilities

- Program flexibility: The ability of a system to run for reasonably long periods without external intervention
- Production flexibility: The volume of the set of part types that a system can produce without major investment in capital equipment
- Market flexibility: The ability of a system to efficiently adapt to changing market conditions

The different types of FMS are

- Sequential FMS
- Random FMS
- Dedicated FMS
- Engineered FMS
- Modular FMS

Sequential FMS: It manufactures one-piece part batch type and then planning and preparation is carried out for the next piece part batch type to be manufactured. It operates like a small batch flexible transfer line.

Random FMS: It manufactures any random mix of piece part types at any one time.

Dedicated FMS: It continually manufactures, for extended periods, the same but limited mix of piece part batch types.

Engineered FMS: It manufactures the same mix of part types throughout its lifetime.

Modular FMS: A modular FMS, with a sophisticated FMS host, enables an FMS user to expand their FMS capabilities in a stepwise fashion into any of the previous four types of FMS.

Today's manufacturing strategy is to seek benefits from flexibility. This is only feasible when a production system is under complete control of FMS technology. Having in mind the Process-Product Matrix you may realize that for an industry it is possible to reach for high flexibility by making innovative technical and organizational efforts. See the Volvo's process structure that makes cars on movable pallets, rather than an assembly line. The process gains in flexibility. Also, the Volvo system has more flexibility because it uses multi-skill operators who are not paced by a mechanical line. So we may search for benefits from flexibility on moving to the job shop structures.

Actually, the need is for flexible processes to permit rapid low cost switching from one product line to another. This is possible with flexible workers whose multiple skills would develop the ability to switch easily from one kind of task to another.

As main resources, flexible processes and flexible workers would create flexible plants as plants which can adapt to changes in real time, using movable equipment, knockdown walls and easily accessible and re-routable utilities.[2]

References:

- [1] en.wikipedia.org/wiki/Flexible_manufacturing_system
- [2] **Shivanand, H.K.** Flexible Manufacturing System. s.l.: New Age International Publishers, 2006.
- [3] **Boncoi, Gh.** Sisteme de productie, vol.I. Concepte si automatizari. Brasov: Ed. Univ.Transilvania,
- [4] **Catrina, D. s.a.** Sisteme flexibile de prelucrare prin aschiere, vol.II. Bucuresti
- [5] **Călin, S., Popescu, T., Jora, B., Sima, V.** Conducerea adaptivă și flexibilă a proceselor industriale.
- [6] **Ganea, C.** Particularitati tehnologice privind prelucrarea pieselor . Universitatea Tehnica Cluj-Napoca:
- [7] **Ganea, Macedon.** Masini unelte flexibile si echipamente tehnologice pentru prelucrarea pieselor prismatice. Oradea : Editura Universitatii din Oradea, 2009. ISBN: 978-973-759-884-4.
- [8] **Niculescu-Mizil, G.** Sisteme flexibile de prelucrare. Buburesti: Editura Tehnica, 1989.
- [9] **Pop, Al.C., Morar, L.** Sisteme integrate de prelucrare. Logistica sistemelor integrate de prelucrare. Cluj-Napoca: Editura Dacia, 1998.
- [10] **Youssef, Helmi A.** Machining technology : machine tools and operations. s.l.: CRC Press, 2008.
- [11] **Marciniak, K.** Geometric modeling for numerically controlled machining. s.l.: Oxford University Press,
- [12] **Pourbabai, B.** Design of a flexible assembly line to control the bottleneck. 1994.
- [13] **Radu, Tarca.** Introducere în Robotică . Oradea : Editura Universitatii din Oradea.
- [14] **Brandl, Dennis.** Design patterns for flexible manufacturing. s.l.: ISA—Instrumentation, Systems, and Automation Society, 2006. ISBN 978-1-55617-998-3