

HOW COULD BE PREVENTED HIGH VOLTAGE DISCONNECTING SWITCHES' COLAPSE IN EXPLOITATION.

Victor Carp

Universitatea din Oradea, victordcarp@yahoo.com

Key words: Ceramics Post Insulators, High Voltage Switches, cracks, damages, economic effects.

Abstract: Within the paper are presented , the main causes of 110V High Voltage Disconnecting Switches collapse in exploitation. Ceramic Cylindrical Post Insulators involved in their construction, often break down, due to some of these causes:

-freeze of condensed/rainfall water, slipped down between the Ceramic Insulator Body and its metallic parts (upper cup and the bottom support) during winter time; -overpass of the nominal moment bending , due to frozen water which covers and increases weight of the connecting cables; -incorrect armoured operation of the Ceramic Cylindrical Post Insulator, which presents „skid core” due to manual technology of production; - incorrect operation of the mechanical systems which rotate High Voltage Disconnecting Switch , by the staff on duty.

During years of exploitation in the electric fields, some of these Ceramic Post Insulators are affected by cracks of different types. Besides, other defects like pores, lack of material, thermic points etc could be at the origin of Ceramic Post Insulators Damage. It is ,of course, more convenient and economic to prevent their breaking in current exploitation. Doing this, we can avoid some very dangerous accidents and save o lot of money and troubles. The usual laboratory proceedings to investigate functional state of Ceramics Cylindrical Insulators are:

- Thermograph in infra-red Methods: The Active Method and The Passive Method,
- Penetrating Liquids Methods ;
- Ultrasonic Investigating System

There have been done examinations at the Electric Fields in Oradea and Alesd, with the Mobile Nondestructive Researches Laboratory and also at the specific laboratories of the Polytechnic University of Bucharest.

1. 110KV HIGH VOLTAGE SWITCHES SCHEME, REPORTED ACCIDENTS AND SOME CAUSES OF THEIR COLAPSE IN EXPLOITATION.

1.1 Construction Elements.

Ceramic Post Insulators which are investigated in this work, are incorporated in the 110KV High Voltage Switches Construction. These Switches enable the horizontal blades opening, having a 110KV nominal Voltage and nominal currents of 1250 – 1600 – 2000 A. These Switches present only a monopole construction. Engineering scheme of such a Rotative Switch is presented in Fig.1.1 and its connecting pole is enclosed.

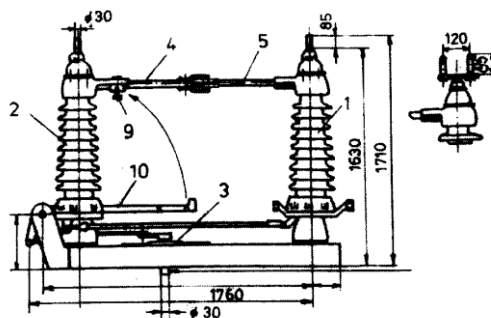

Fig.1.1. Scheme of 110 kV Rotative High Switch.

Ceramic Insulators 1 , 2 can swivel, turning round with 90° under the action of a mechanic or an electrical device 3 . On the rods 4 and 5 , are set electrical contacts 6 ,7 and 8. They are mounted in a vertical position, on a metallic frame, on which are also set up all mechanic action devices.

Manufacturer „Electroputere S.A.” – provides all required needs concerning setting up, adjusting and probation. It also provides a 12 -18 months guarantee period.

1.2. Reported Accidents to the Beneficiary

Electrical field events collected during a long period, 01.01.2005 – 01.06.2007 showed that, some of these Ceramic Post Insulators have been broken in exploitation, both at the upper metallic cup and at the bottom metallic support of the ceramic rotating insulators. In fig.1.2. is presented such an accident. These accidents were traced out like follows:

- 4,4% through direct examination under electric voltage;
- 30,4 % direct examination without voltage ;
- 39,1% breakings with no other circuits damage;
- 26,1% breakings with other circuits damage.

The brakes were located at the upper metallic cup, most of them and also at the bottom metallic support.



Fig.1.2. Ceramic Insulator broken from the metallic bottom support

1.3. Some Causes of 110 KV High Voltage Disconnecting Switches Ceramic Insulators Colapse.

According to electrical fields events, reported by the beneficiary, these kind of accidents happened to the old 110KV High Voltage Switches, having more then 10-15 years length of service.

Geographic areas into which these accidents have been located are: Harghita, Bihor, Salaj, Cluj, Baia Mare, Satu Mare.

Reported breakings of the Ceramic Post Insulators, used in 110KV High Voltage Switches, are the action result of one or more of the following causes:

1. Metallic Parts cracking during the winter time, when the protection coat of paint falls and the water is absorbed by the bounding cement. Freeze of the condensed/ rainfall water slipped between Ceramic Insulators and its metallic parts, the upper cup and the bottom support, or absorbed by the bounding cement, involves an important volume increasing of iced water. Consequently, microscopic cracks appears both into the metallic parts and to Ceramic Post Insulator. In time, these cracks become larger and

larger . There were cases when such fissured metallic cups fell themselves from the Ceramic Insulator.

2. During winter time, due to the hoar frost and water frost, the weight of electric bounding conductor , may increase very much, exceeding the maximum load of 4000 N, which may result in Bending Moment overtaking.
3. Rigid electric rod conductors, inadequate used in exploitation, may become stiff and lead to loads increasing;
4. Bounding paste of the metallic parts on the Ceramic Insulators (Sulph paste, and Portland cement now) was many times unsuitable, because of economic reasons.
5. Armed operation of the Ceramic Insulators with their metallic parts, were made unsuitable, sometimes. Bounding cement layer, in some cases, were not symmetrical distributed, and there were found important excentricities. This fault is called „running core”.
6. Getting stuck / blocking of the Mechanic Systems which rotate the High Voltage Switch, concerning following aspects:
 - blocking of the Levers System which rotate the Switch Cylindric Insulators;
 - unsuitable maintenance of the Switch Electric Contacts , which require a thoroughly half-yearly regulation,
 - axial bearings lubrication.
7. Incorrect operation of the mechanical systems which rotate High Voltage Disconnecting Switch , by the staff on duty. They used to knock with a hammer the blocked levers of the mechanic system.

2. LABORATORY PROCEEDINGS TO INVESTIGATE CERAMIC INSULATORS 'INTEGRITY

Objectives of this work consist in setting up the suitable laboratory proceedings to investigate the Ceramics Insulators' Integrity, which means to display the presence of different types of Cracks into the ceramic Body or into the metallic Caps.

There have been done examinations at the Electric Fields in Oradea and Alesd, with the Mobile Nondestructive Researches Laboratory and also at the specific laboratories of the Polytechnic University of Bucharest.

2.1. Thermography Method to Investigate Ceramics Cylindrical Insulators' Integrity – Active Method

Thermography in infra-red by impulses, the Active Method, involves an adequate system of thermography apparatus, able to create a thermic image which can be display into a spectral range. Such a system consist of a ThermoCam PM 350 and some other components and has been used to the selected Ceramics Cylindrical Insulators, which have been taken off from the Electric Fields. The thorough examination of these selected Ceramic Post Insulators, used in the structure of 110 KV High Voltage Disconnecting Switches, put in evidence the following types of defects:

- Ceramics Post Insulators with no defects, which can go on to be used without problems ;
- Ceramics Post Insulators containning one or twe small cracks localized at the base of these, which can be maintained in use, but controlling the craks developing periodically ;
- Ceramics Post Insulators containning deadly defects, like small and large cracks (Fig.2.1.), penetrated cracks, which must be taken off from their use, in the structure of 110 KV High Voltage Disconnecting Switches.

Examination of the Running State of the Ceramics Cylindrical Insulators, selected before from the Electric Fields, by this Active Thermography Method, has conclude to the following conclusions:

- Some of the investigated Ceramics Insulators presents original defects like: cracks, pores, lack of material, thermic points ;
- Thermic Points localized at the base of some Insulators, may generate a „ V „ small slit, which in time, during exploitation, may penetrate through the material, to the surface ;
- During Investigation of the Ceramics Post Insulators, the Disconnecting Switcher must be put off the function

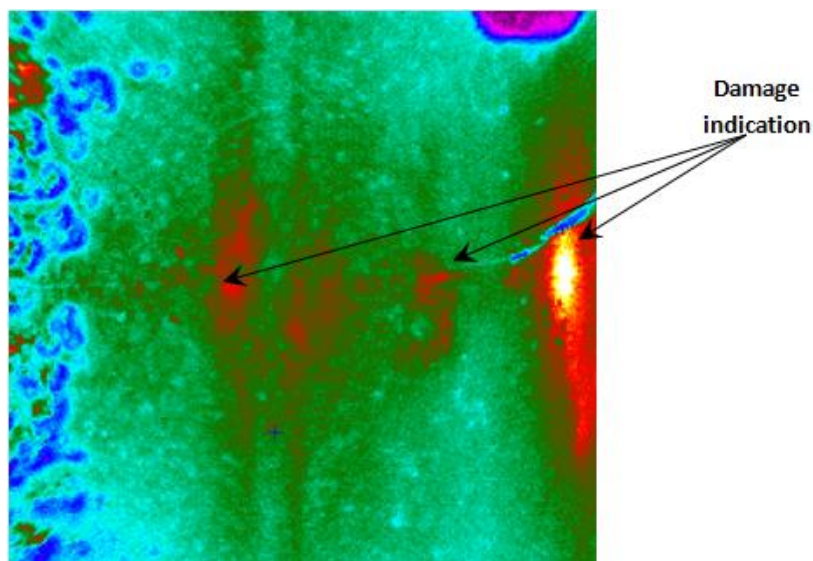

Fig.2.1. Small and large cracks in the Ceramics Post Insulators.

2.2. Thermography in infrared Method to Investigate Ceramics Post Insulators' Integrity – Passive Method

In the case of this method, we keep all the above specification, stating that , the equipment consists ,only in a Thermocamera THERMOCAM SC 640. This camera uses the inner warm of the ceramic material. By applying The Thermography in infra-red Method, called Passive Method to the selected Ceramic Insulators directly at the Electric Fields in Oradea , Alesd, where they were mounted in the 110 KV High Voltage Disconnecting Switches' structure, there have been found , besides the usual defects presented before by the Active Method, following kind of defects:

- Ceramics Insulators with a large crack in the Metallic Cup, as in Fig.2.2;
- Penetrated Cracks to the Base of the Ceramics Insulator, as in Fig.2.3;
- Small and large Cracks in the Ceramics Insulator Body.

All these defects have been confirmed by direct and optical examination.

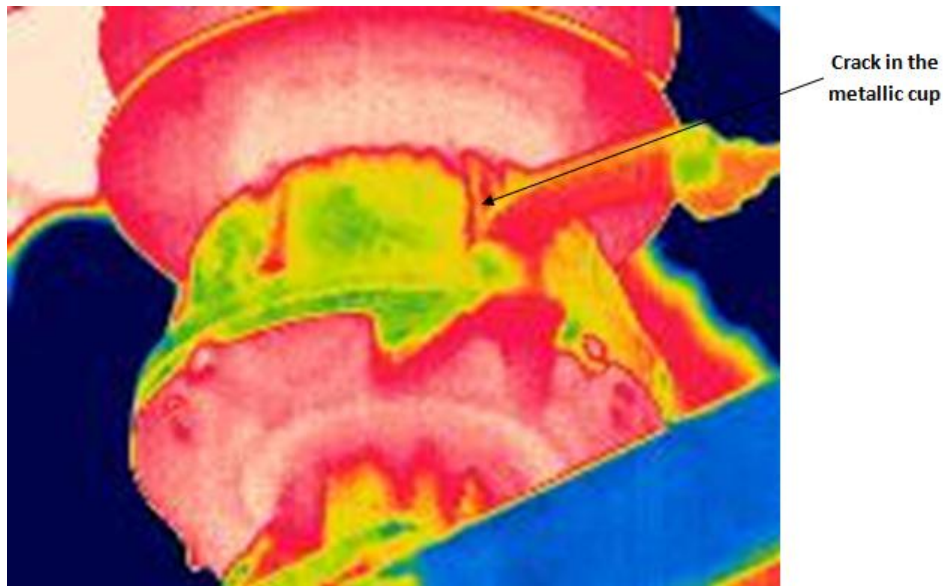

Fig.2.2. Ceramics Insulator with a large Crack in Metallic Cup.

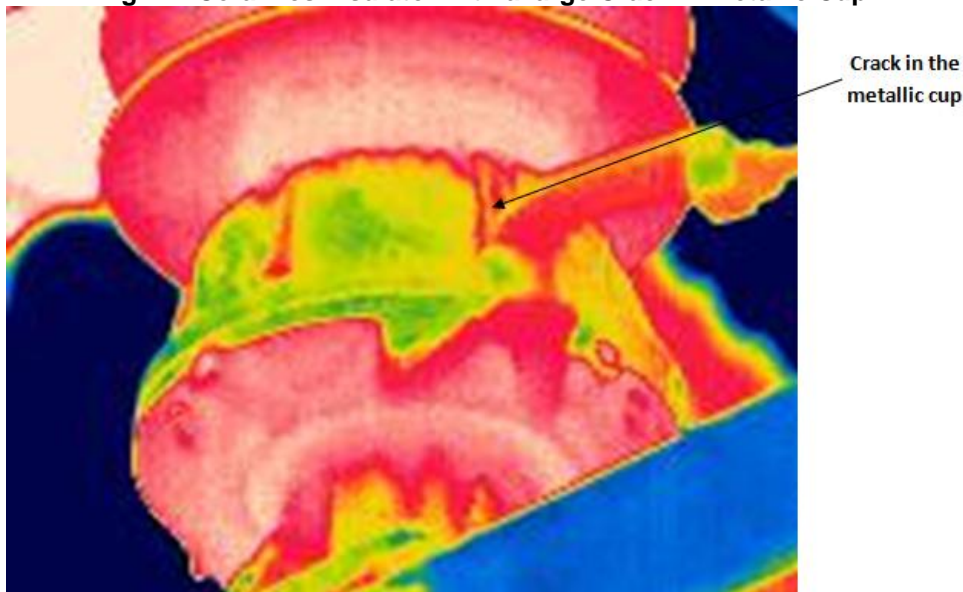

Fig.2.3. Penetrated Cracks to the Base of Metallic Cup.

So we may conclude that The Thermographic in infra-red Method is appropriate to put in evidence the Ceramic Post Insulators Damages, by Direct Control, without taking off the use of Disconnecting Switches. In fact this Passive method does complete examination performed through the Active Method.

2.3. Penetrating Liquids Method

As it is known, nondestructive laboratory proceeding called “The Penetrating Liquids Method” is applicable to detect all kind of superficial defects like pores, cracks, lack of material, pierces, stratifications, breaks and so on the body of different pieces and semi-finished products. Work procedures were the ones recommended in STAS 10214 – 84, annexes A, B1,B2,B3. Specific equipments, like ultraviolet and normal lamps, penetrating liquids were all of them of high quality. Work proceedings have been performed by qualified laboratory staff.

There were inspected both important zones, the one between inferior cup and the first row of the ceramics body and the one between superior cup and the last row of ceramics material.

In the following photos are presented some very dangerous defects localized on these zones. Through this investigations we tried to guess if the cracks founded in the metallic cups, could have any influence on Ceramics Insulator's Body deterioration.

Certainly, such a supposition is not a rule. The metallic cups cracking might not influence ceramic's body splitting and vice-versa. There have been performed analyses to discover the propagation process of the cracks , from the core to the surface of the ceramic body. Some of the inspection remarks are presented next, on the following images in Fig.2.4. and Fig.2.5.



Fig.2.4. Longitudinal fissure in the metallic cup.



Fig.2.5. Deep crack on the base of the ceramics body.

2.4. Ultrasonic examination methods.

As it is well known, the ultrasonic pulse-echo testing system is applicable to detect all kind of superficial defects like pores, cracks, lacks of material, pierces, stratifications, breaks on the body of different pieces and semi-finished products. Work procedures were the ones recommended in ASTM E 317–98–Standard practice, Code ASME Sect. V, Art. 6 , Art. 24; ASME Sect. III NB ,ND; ASME Sect. IX, Ed. 98; SR EN 473-2003 . Specific

equipments, like Deprecator scope KRÄUTKRAMER , USM 35 X and different types of palpates, are all of them of high quality.

Work proceedings have been performed by qualified laboratory staff, according to SR EN 12223- 2001 Nondestructive Examination. Ultra sonic Examination. Our investigation started with some Ultrasonic Examination, directly in the Electric Fields at Alesd and Oradea and afterwards in the nondestructive research laboratories of Bucharest Politehnica University on very different Cylindrical Ceramics Insulators.

There have been used “normal palpates “, initially applied on the exterior surface of the Ceramic Body on both important zones, the one between inferior cup and the first row of the ceramics body and the one between superior cup and the last row of ceramic material. No have been found discontinuities. In the next phase, there have been examined the inferior zone, through the metallic cup hole, as is presented in Fig.2.6 .

There have been found “discontinuities indication”, signalized in some diagrams (DAC –Distance Amplitude Curve) like in in Fig.2.7. ,most of them at the bottom part of the ceramic body, covered by metallic cup, but also along the ceramic body and at the top of it.

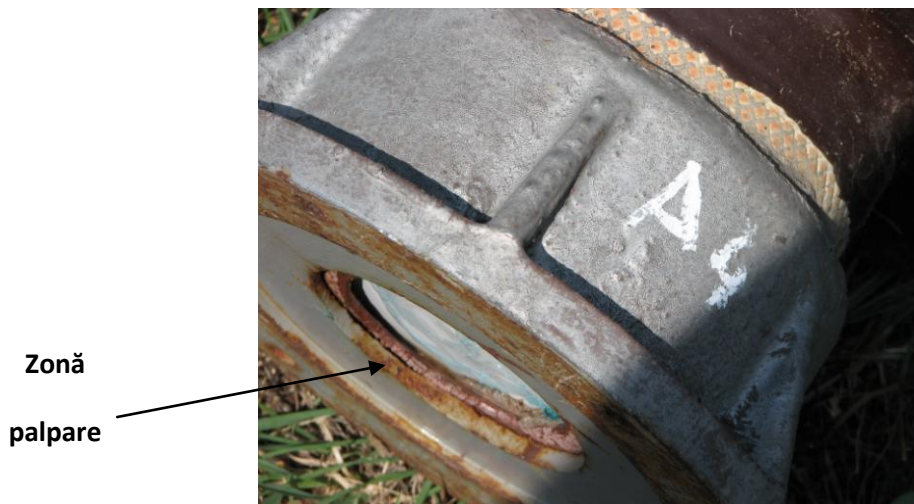

Fig.2.6. Examination zone on the base of Ceramic Post Insulator.

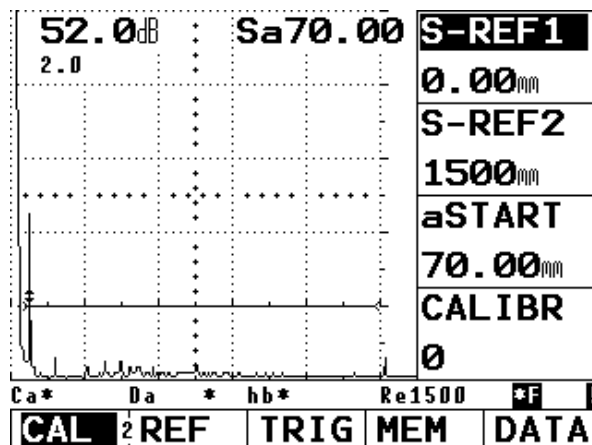

Fig. 2.7. Discontinuity indication at 70 mm.

3. CONCLUSIONS

Examination of the Running State of the Ceramics Cylindrical Insulators, selected from the Electric Fields, by the usual Laboratory Methods, concluded to the following aspects:

- Some of the investigated Ceramics Insulators presents original defects like: cracks, pores, lack of material, thermic points ;
- Thermic Points localized at the base of some Insulators, may generate a „ V „ small slit, which in time, during exploitation, may penetrate through the material, to the surface ;
- During Investigation of the Ceramics Post Insulators, the Disconnecting Switches must be put off the function.
- Taking off from the electric power the disconnecting switches, is possible to examine the Ceramics Insulators integrity, at the place, were they are mounted in a structure, by applying Penetrating Liquids Method, to put in evidence cracks, holes, pores, lack of materials and so on, which may have correspondence with deep inner defects.
- Taking off from the electric power of the disconnecting switches, it is also possible to investigate the Ceramics Insulators 'integrity , at the place, by applying Ultra Sonic Method, to put in evidence cracks, holes, pores, lack of materials and so on, which may have correspondence with deep inner defects;
- Taking account that 30 – 40 % of the Ceramic Post Insulators investigated, have presented “discontinuities indication” of some possible defects, this method is valuable to prevent accidental damages of the disconnecting switches;
- Ultra Sonic Method is also very practical one, as it and may be complimentary to other nondestructive laboratory procedures like thermograph in infra-red by impulses method and penetrating liquids method.

References

- [1] Carp V, Felea I, Veres M, - „Experimental Researches concerning the 110 KV HighVoltage Disconnecting Switches”, Scientific Raport, 2007/2008, University of Oradea
- [2] Amza Ghe, Carp V, Dumitrascu C. – Raport la Contractul de cercetare de cercetare stiintifica privind, metodele de examinare nedistructiva a izolatoarelor ceramice, incheiat intre Politehnica Bucuresti, facultatea IMST si Universitatea din Oradea, 2007/2008.
- [3] Carp V. “Laboratory Proceedings to Desplay Deep Cracks on Ceramic Insulators used in 110KV High Voltage Disconnected Switchers” Analele Universitatii din Oradea, Fascicula I.M.T. Vol. V. 2008, ISSN 1583- 0691,
- [4] Carp V. “Penetrating Liquides Methods to show Dangerous Cracks on Ceramic Post Insulators Structure” Analele Universitatii din Oradea, Fascicula I.M.T. Vol. 3. 2009, ISSN 1583- 0691.
- [5] Carp V. – “Laboratory Proceedings to Display Deep Cracks and other Major Damages in Ceramic Bodies of 110KV Disconnecting Switches” – Revista de Tehnologii neconventionale nr. 3, 2009., Editura Politehnica – Timisoara, ISSN – 1454-3087;