

## **THE DESIGN OF THE TECHNOLOGICAL HEAD**

**Ioan Pantea**

University of Oradea, [ipantea@uoradea.ro](mailto:ipantea@uoradea.ro)

**Keywords:** toothed knives, milling head, gears.

**Abstract:** The accuracy of execution of the bevel gears with curved teeth is so high, that the normal technology of the relief of the toothed knives does not satisfy the requirements of that special processing. Bevel gear cutting heads with curved teeth have a large number of knives between 8 and 28, placed on relatively large diameters between 88.9 and 406.9 mm. The large numbers of knives from a head, make that for the relieving to be required a large number of double strokes for a single rotation of the stroller gear cutting tool. The aim of that work is to demonstrate that the helical processing of the side and top surfaces of the toothed knives, according to the same law for generating, can replace the radial or angular relief with cam, the processing being made on classical grinding machines or on thread grinding machines, and the deviations of profile of the knives being processed are comparable with those of companies producing tools for gear cutting.

### **1. Introduction**

The technology for relief used by the companies that produce machine tools and tools used for gear cutting for the curved teeth bevel gears is unknown. The profiling of these knives is difficult, if not properly executed; after a number of grindings appear deviations of the profile, deviations that affect negatively the gear cutting process. They have a too high frequency for the inertial forces that appear to be taken over by the rigidity of the system. The resulting vibrations and shocks generate clearance of the guide ways. The springs that keep the contact on the cam that controls the movement of relieving, no matter how strong, over a certain motion frequency cannot maintain this contact anymore and experience other negative phenomena. All these are transposed on the relieved surfaces changing the knife profile. The assembling on the cross sled of grinding lathes devices is difficult, due to the large number of knives of the head and the small space between them. The grinding wheel, processing a knife of the technologic head, touches the adjacent knives, so that special heads should be used with a smaller number of knives, raising the cost of the processing. In our country the attempting of knives profiling using cam devices were abandoned, because after a small number of grinding the profile of the knife no longer meets the conditions imposed. The large number of existing gear cutter machines in the country requires the identification of more economical and precise methods for the relief of knives from the gear cutting heads with which these machines are equipped.

### **2. The Design of the Technological Device**

The design of the technological device is made in close accordance with the design of the Gleason type toothed cutter holder. It has been chosen as size for the device used at the attempting the nominal diameter of 6", in the middle range of sizes most commonly used. The calculation formulas are used to design the technological device too, with the help of which are processed the knives that equip the toothed heads with the size 6. Geometry of the device is formed by: the nominal diameter of the device is chosen depending on the nominal diameter of the head from table 1 considering that a knife has to process a certain number of gear modules.  $D_n = 154. \text{mm}$ ; outside diameter:  $D_e = 160 \text{mm}$ ; channel arrangement diameter; depending on the outside and inside diameter of the head; the angle between the channels is chosen provided that space between the knives to be at a minimum; with the increasing of the diameter the angle between the channels changes;

cylindrical helix pitch; the positioning angle at the tip of the knife it has to be optimal. The specialized Literature indicates for this angle the value of 11 to 13 degrees.

**Table 1 of Nominal diameters of gear cutting heads and the height of the working knives**

Nominal diameter D		Height tooth h [mm]	Nominal diameter D		Height tooth h [mm]
["]	[mm]		["]	[mm]	
3 ½"	88.9	8.7	7 ½"	190.5	12.50
4 ½"	114.3	9.5	9"	228.6	14.30
5"	127	9.5	12"	304.8	19.50
6"	152.4	9.5	16"	406.4	19.50

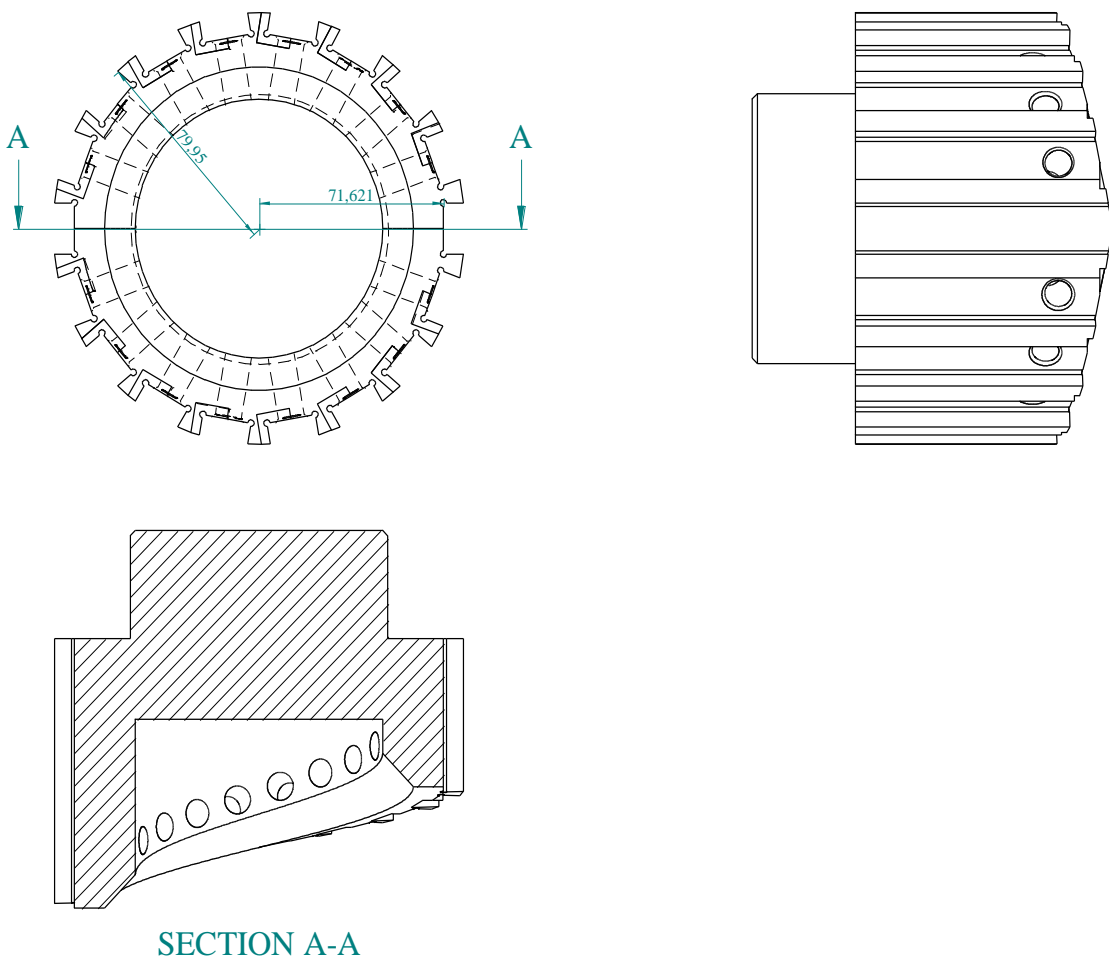

**Figure 1. Technological Head**

### 3. Implementation of the Experimental Device

The body of the device, figure 2, is manufactured on classical machines, for milling the channels it is used a dividing head. The division of the body (no. of channels) is done so that the distance between the channels to be a minimum, leaving space for buffering of the raising of the profile.



*Figure 2. Technological device done*

Corrections of the channels are done on the machine for grinding grooves. The frontal helical surface is processed on a CNC milling machine – Fadal. When processing the frontal helical surface it will be taken into consideration the pitch of the cylindrical propeller. One drawback of the technological device is the fact that the size of the blade mounting channel (width) is fixed. Nevertheless, following the main geometry of the Hardac tothing heads, we notice that for the entire range of the bevel modules executed on the Gleason machine are being used four dimensions of channel width, that means there is no need of four technological devices for the manufacturing of the entire range of knives.

#### 3.1 Constructive Varieties Regarding Technological Devices for Assembled Grinding

The technological device designed for testing is shown in figure 3. The components of the device are: 1- body, 2- outside right knife, 3 – outside left knife, 4 – fixation pin, 5 – screw M12, 6- washer A12. The semi- finite knives are assembled on the circumference of the device without space being allocated for division, as it follows: on the first semicircle (from 0 to  $\pi$  ) knives that are cutting on the right, on the second semicircle (from  $\pi$  to  $2\pi$  )

knives that are cutting on the left. For a device we want to process internal knives and external knives it is possible to use the body with the minimum diameter for the channel layout (the one for processing of the internal knives); for the processing of the external knives the knives adjustments will be made with a set of track. The device can be constructed with the continuous helix on 2, thereby achieving a greater number of teeth corrected (the heads with large diameters have up to 28 knives). The design of the devices was done in the SOLID EDGE software, software which allows generations of 3D bodies, their assembly and listing.

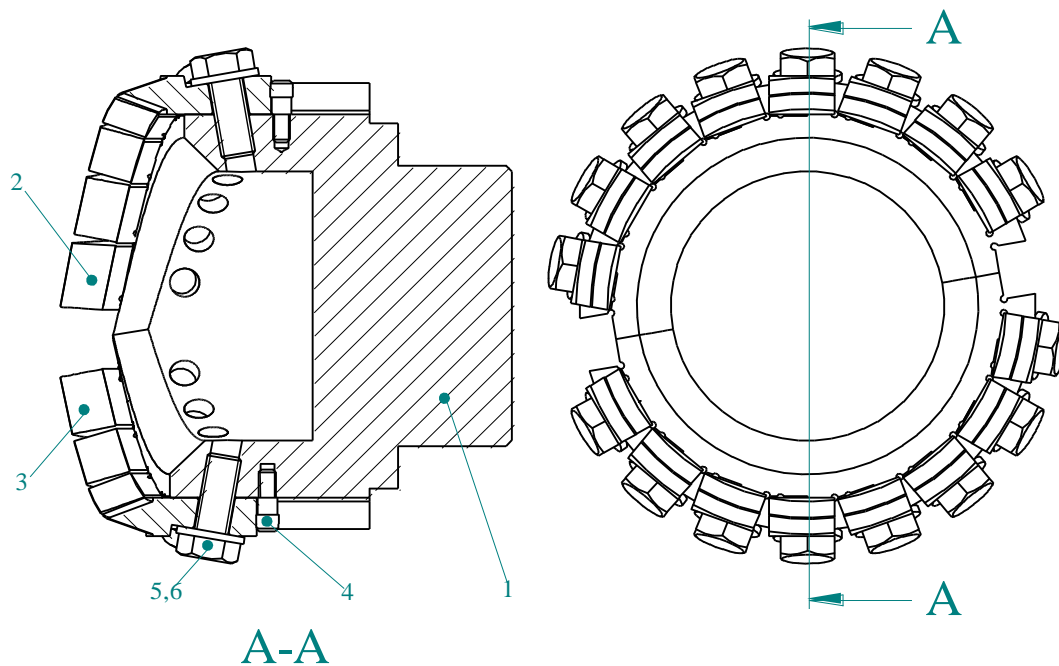

**Figure 3 The components of the technological head**

#### **4. Conclusions**

The profile of these knives is part of the helicoids, it cannot be wrapped by cylindrical or conical grinding tools; in operating conditions, it takes part at a complex processing process by rolling or copying etc., as well as at a degradation process, which modifies the normal profile of the gear tooth.

The technological process of implementation of knives requires special processing for the profile execution. In operating conditions, it shows up the wearing of all the knives, especially at the tip of these where the heat from the cutting process concentrates. To remove is done the grinding of the whole set of knives by grinding the face of clearance.

#### **References:**

1. Litvin F. L., Gear Geometry and Applied Theory. University of Illinois, Chicago. PTR Prentice Hall, Englewood Cliffs, New Jersey 0763. ISBN-13-211095-4, 1994.
2. Minciu, C., Scule aşchietoare. Îndrumar de proiectare. Editura tehnică, Bucureşti, 1995.
3. Pantea I., Contribuţii privind tehnologia sculelor de danturat roţi dinţate conice cu dinţi curbi. Teză de doctorat, Universitatea din Oradea, 2004.