

PREDICTION STRATEGY FOR THE WIND TURBINE BEHAVIOUR BY CONSIDERING THE INFLUENCE OF THE BLADES NUMBER

Mihai-Tiberiu Lates, Per Ulrik Hansen

“Transilvania” University of Braşov, Product Design and Robotics Department,
VIA University College, Horsens, Denmark
latesmt@unitbv.ro, puh@viauc.dk

Keywords: wind turbine, blade, power curve, prediction.

Abstract: According to the real functioning conclusions of a small scaled model and according to the simulations, important predictions can be formulated for the behavior of a real system. One of the parameters which is influencing the instantaneous power produced by a horizontal axis wind turbine is the number of the blades. The paper presents a prediction strategy for the behavior of a real wind turbine system which is based, on one hand, on the theoretical study of the blades number influence and, on the other hand, on the testing of a small scaled system.

1. INTRODUCTION

The parameters which are influencing the produced power from a wind turbine, at the same wind speed, are represented mainly, by: the rotor's axis position (horizontal or vertical); the number of the blades; the shape of the blades; the blades pitch angle (the blades orientation angle); the diameter of the rotor. The influence of these parameters can be estimated by developing theoretical models or/and by testing the real systems or small-scaled systems.

The aim of the paper is to identify a prediction strategy for the wind turbine behavior by considering the influence of the blades number. According to that, the strategy is based on two levels: a first level, which consists in the development of a theoretical model; a second level, which is accomplished by testing a small-scaled wind turbine system [6, 7, 8].

According to the simulations of the theoretical modeling and according to the testing results, important predictions can be formulated for the further functioning of the system. The idea starts from this point: the need to design a system which allows interaction – in a specific way - with the environment and learn from these interactions. By specific way we understand an interaction based on known behaviors collections. By learning from the mentioned interaction we understand the possibility to develop the behaviors collections [6, 7, 8].

2. THE PRODUCED POWER

According to the theory, a wind turbine is producing electrical power by considering the relation [3, 4, 5, 9]

$$P = 0.5 \rho v^3 A C_p, \quad (1)$$

where ρ is the air density ($\rho=1.2255 \text{ kg/m}^3$ at the sea level); v – the wind velocity; A – the rotor's swept area; C_p – the power coefficient [3, 4, 5, 9]

$$C_p = \eta_m \eta_e \eta_a, \quad (2)$$

where: η_m is the efficiency of the mechanical transmission ($\eta_m=0.95 \dots 0.97$); η_e – the efficiency of the electrical components ($\eta_e=0.88 \dots 0.92$); η_a – the aerodynamic efficiency.

According to the fluid dynamics theory, *Betz* has established in 1919, that the maximum amount of the kinetic energy of an air flow which can be converted into mechanical energy is not bigger than 59%; this value was established for an idealized theoretical model.

In the case of the wind turbines, the value of the C_p coefficient is influenced by: the type of the wind turbines axis (horizontal or vertical); the rotor's diameter; the number of blades; the rotor's velocity; the wind speed. A common parameter which is influencing the power coefficient is defined as [3, 4, 5, 9]

$$\lambda = \frac{v_r}{v}, \quad (3)$$

where v_r is the linear velocity of the blades end and v is the wind speed.

In the case of a given diameter for a horizontal axis wind turbine, at the same wind speed, the results of the test are showing that for a small number of blades, to obtain a higher value for C_p , big values for λ are necessary (the same reason is considered for the small wind turbines – they have higher values for the rotor's velocity at small wind speeds than the big wind turbines). Further, the experiments on a small scaled model will show the blades number influence on the C_p coefficient, so on the produced electrical power.

3. THE EQUIPMENTS

The air flow is generated by using the fan from the figure 1 [1, 2, 10]; A represents the inlet area of the air; B – the outlet area of the air flow; C – the connection socket to the current cable; D – the selection switch of the wind speed. The calibration of the fan is made by identifying the dependencies between the position of the switch D and the value of the wind speed at the wind turbine. The air flow speed is measured by using the anemometer with cups – figure 2.



Figure 1: The fan

The anemometer is characterized by: A – the on/off switch; B – the switch used to select the measuring unit; C – the measuring unit (KM/H – km/h, KTS – knots, M/S – m/s, MP/H – m/h); D – the instantaneous wind speed display; E – the maximum value of the instantaneous wind speed display; F – the average value of the instantaneous wind speed display; G – MX (maximum value), AV (average value); H – the display for the *Beaufort* scale; I – the battery tray; K – the threaded hole, used for the mounting on the base plate A.

The horizontal axis wind turbine (figure 3) contains [1, 2, 10]: the blades (2, 3, or 4) are mounted on the hub *A* through the hole *B*; the connection sockets *C* to the generator and to the tachogenerator; the threaded pins *D* which are used to fix the blades on the hub; *E – G* positioning holes of the wind turbines on the plate base.



Figure 2: The anemometer



Figure 3: The wind turbine

The *A* graded protecting screen (figure 4) is useful to fix the pitch angle of the blades; the *B* magnets are used to fix the protecting screen on the base plate.

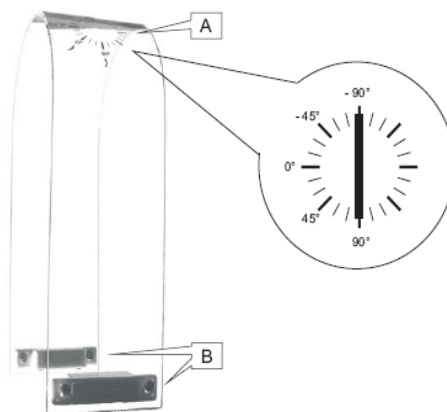

Figure 4: The protecting screen

The electrical signals (the current and the voltage) are measured by using the multimeter from the figure 5 [1, 2, 10]: *A* is the display for the measured parameters; *B* – the switch which is used to select the measured parameters; (OFF – the multimeter is off; AVC – measuring the AC voltage by connecting to the sockets *D* and *E*; DCA – measuring the DC current by connecting to the sockets *D* and *E*; 10A – measuring the DC current by connecting to the sockets *C* and *E* – max. 10 A, connection without safety fuse; OHM –

measuring the electric resistance by connecting to the sockets *D* and *E*; DCV – measuring the DC voltage by connecting to the sockets *D* and *E*; *C* – connection socket + connecting cable, 10 A DC; *D* – connection socket + connecting cable V / Ω / mA; *E* – connection socket + connecting cable.

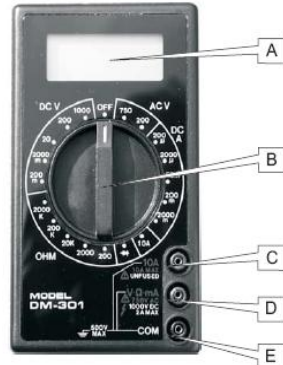

Figure 5: The multimeter

The load (figure 6) is represented by a load with a 100 Ω electric resistance and the maximum power of 2 W and contains: *A* – the generator’s connection; *B* – the multimeter’s connection, to measure the voltage; *C* – the multimeter’s connection, to measure the current; *D* – the rotating knob which can adjust the electrical resistance.

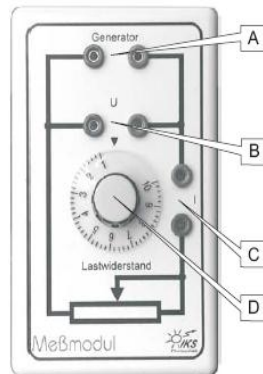

Figure 6: The load

The plate base (figure 7) is has: the *A* cavity used for the mounting of the fan; the *B* pins used to fix the wind turbine; the *C* channels used to mount the protecting screen; the *D* channel used to fix the shutter screen; the *E* zone used to punt the testing modules and the measuring devices; the *F* knob used to fix the elastic wires of the technical manuals; the *G* slot used to fix the base plate in the box.

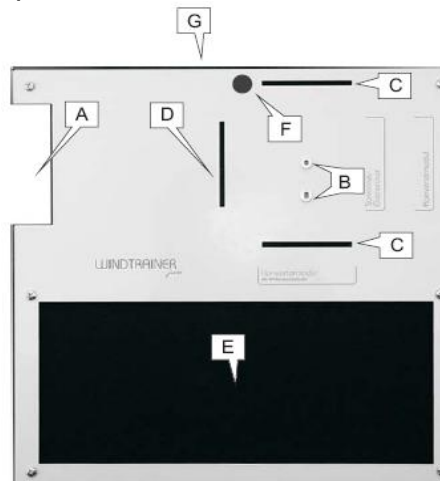

Figure 7: The plate base

3. THE TESTS

For the tests, the test rig from the figure 8 is set up, according to some specific aspects:

- the measuring of the voltage generated by the wind turbine is achieved by a multimeter, by fixing its switch on DCV 20 V;

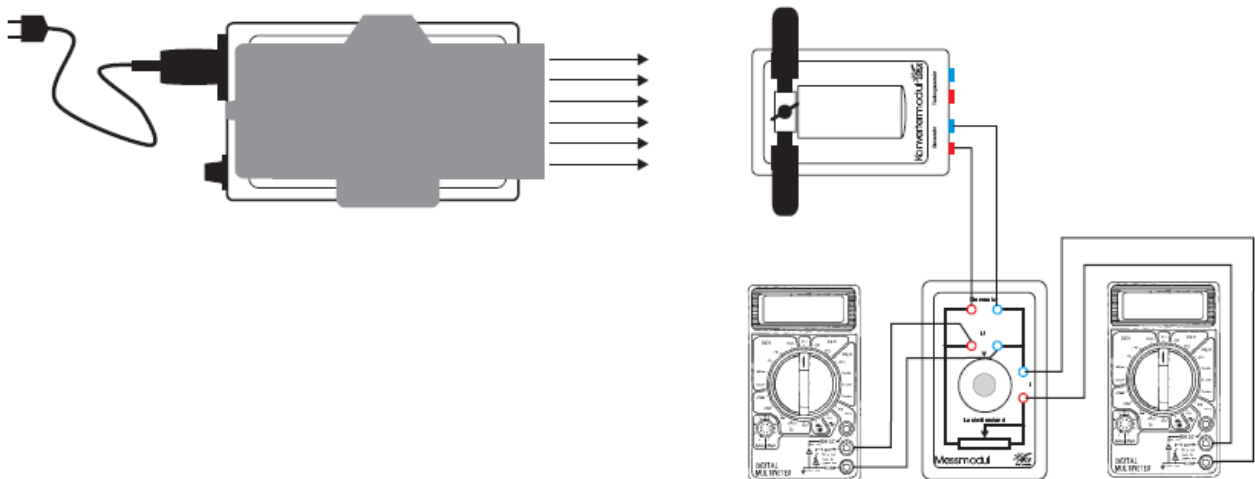

Figure 8: The test rig

- the measuring of the current generated by the wind turbine is achieved by a multimeter, by fixing its switch on DCA 200 mA;
- the wind speed is adjusted by rotating the switch *D* of the fan, from the position 0 to 10;
- the wind speed is measured by using the anemometer which is mounted on the base plate, instead of the wind turbine (figure 9);



Figure 9: The test rig with the anemometer

- for each position of the rotating switch *D* of the fan, the voltage and the current are measured (figure 10);
- the parameters which are used in the measurements, are represented by: the number of blades (2, 3 and 4, respectively); the shape of the blades – straight; the

pitch angles of the blades – 45°; the wind speed – according to the position of the switch *D*; the electric resistance of the load – 50 Ω.

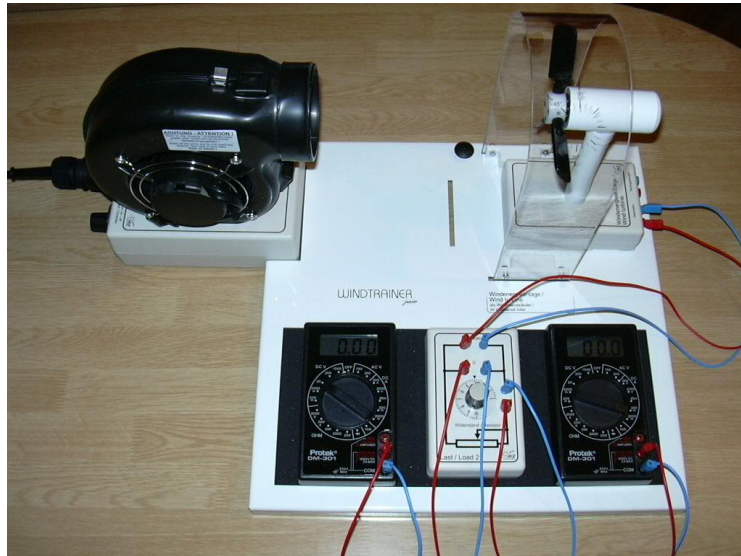

Figure 10: The test rig with the wind turbine

4. THE RESULTS

For each values of the voltage and of the current (by considering 2, 3 and 4 blades, respectively), the electrical power is calculated with the relation

$$P = UI, \tag{4}$$

where *U* is the voltage and *I* is the current generated by the wind turbine.

Figure 11 shows the variation of the power curve for the three cases of rotors: with 2, 3 and 4 blades. According to the instantaneous power developed by the wind turbines, the case of 3 blades is most efficient (at the same wind speeds, this is the wind turbine which assures the highest values for the produced power).

The power curve

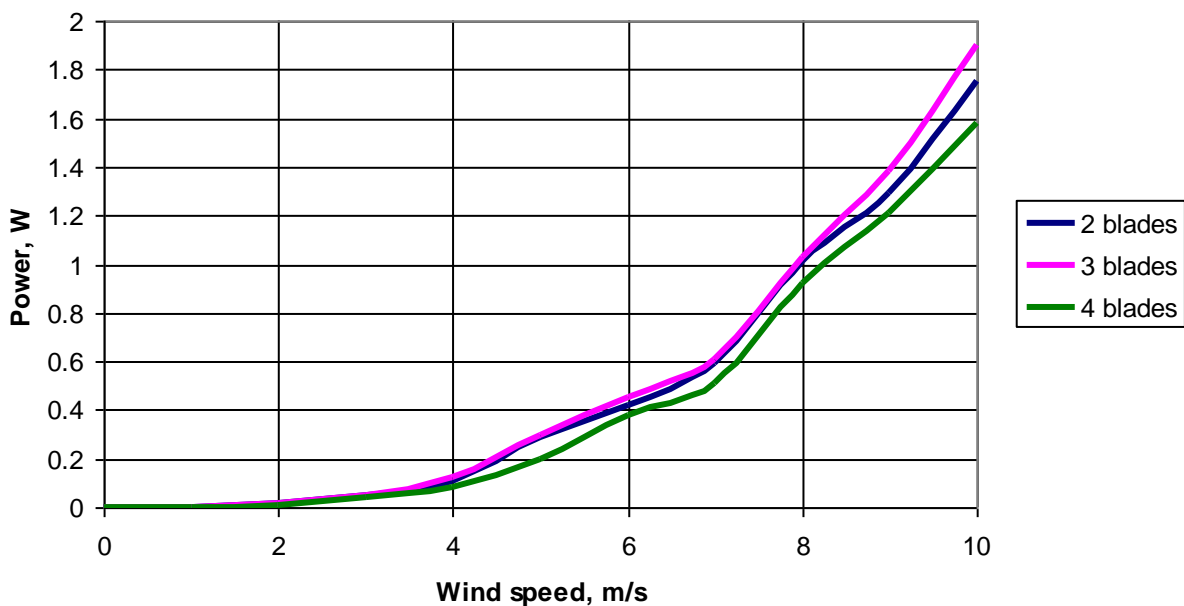

Figure 11: The power curve

The power coefficient C_p has a relative variation (according to the 3 blades wind turbine) as it is shown in the figure 12; generally, C_p is decreasing – the exception is for small wind speeds (less than 3 m/s), when the 2 blades wind turbine assures a higher efficiency.

The variation of the power coefficient

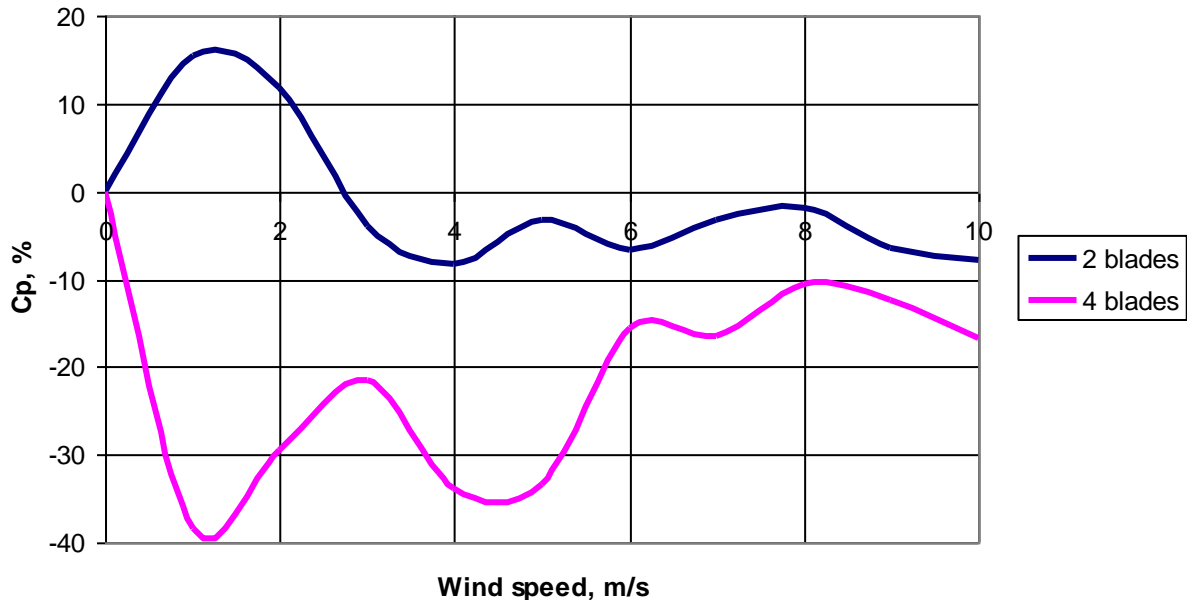

Figure 12: The variation of power coefficient, relative to the case of 3 blades

Figure 13 shows that for small values of the wind speed (f. e. 1 m/s) higher instantaneous powers are produced by the 2 blades wind turbine.

The generated power, at 1 m/s

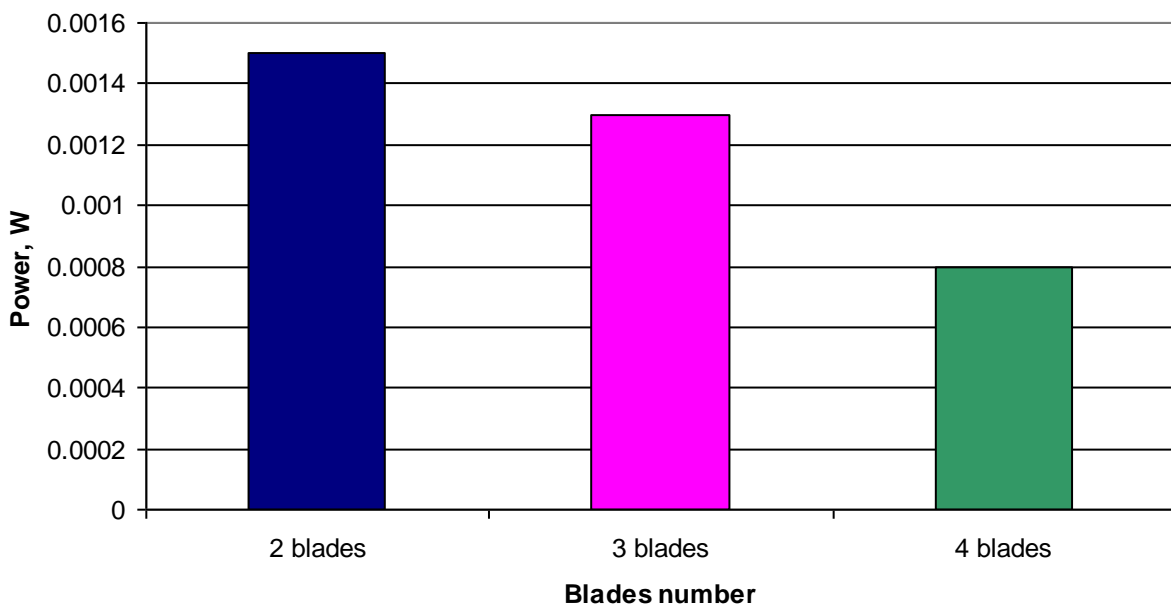

Figure 13: The generated power at 1 m/s

5. CONCLUSIONS

The testing results are showing important conclusions regarding the wind turbine behavior, depending on the rotors blades number: the highest efficiency of the wind turbine is for the variant with 3 blades (in this case the power coefficient C_p has the highest values; the 4 blades variant assures the smallest value of the power coefficient; for small wind speeds (less values than 3 m/s), the 2 blades variant is the most efficient; due to small values of the inertia, for small wind speeds, the 2 blades variant assures higher instantaneous powers and also, the cut-in wind speed has smaller values.

According to the conclusions, qualitative conclusions can be formulated for the wind turbines, generally. By learning from the testing of the small scaled wind turbines, we understand the possibility to develop the behaviors collections for the large scale wind turbines. In conclusion, the 3 blades wind turbines will assure higher aerodynamic efficiencies, excepting the cases of the small value wind speeds (in this case, according to the cut-in wind speed, the 2 blades wind turbines is preferred).

References

- [1] Kunsch, H., Schröder, M. Windtrainer junior. Experiments on Wind Energy. Instructions. Version 02/2007. Kassel, Germany (2007).
- [2] Kunsch, H., Schröder, M. Windtrainer junior. Experiments on Wind Energy. Solutions. Version 02/2007. Kassel, Germany (2007).
- [3] M. T. Lateş. Aspects regarding the small power type windmills implementation in Romania, CD Proceedings of International Conference on Sustainable Energy, 7 – 9 july, 2005, Braşov, România, (2005).
- [4] M. T. Lateş, R. S. Lateş. Power curve experimental determination of an AirX type wind turbine. Proceedings of the 2008 IEEE International Conference on Automation, Quality and Testing, Robotics (AQTR 2008) THETA 16, Cluj Napoca, Romania, 22 – 25 May 2008, pp.247-250, (2008).
- [5] M. T. Lateş. Power curve determination for a small scaled wind turbine. In: Analele Universităţii din Oradea, Fascicula Management şi Inginerie Tehnologică, vol. VIII (XVIII), Editura Universităţii din Oradea. pp.324-329. (2009)
- [6] Pozna, C. a. o. New results in modeling derived from Bayesian filtering. Journal of Knowledge Based Systems. Vol. 23, Issue 2, March 2010, pp. 182 – 194.
- [7] Pozna, C. a. o. On the design of an obstacle avoiding trajectory. Method and simulation. Journal of Mathematics and Computers in Simulation. Vol. 79, Issue 7, 2009, pp. 2211 – 2226.
- [8] Pozna, C. a. o. Characteristics of a New Abstraction Model. Proceedings of the 4th International Symposium on Computational Intelligence and Intelligent Informatics. Luxor, Egypt. October 21 – 25, 2009, pp. 129 – 134.
- [9] B. Sorensen, Renewable Energy, Second Edition, Academic Press, Roskilde – Denmark (1997).
- [10] www.iks-photovoltaik.de.