

MECHATRONICS IN THE LIFE OF AN AUTOMOBILE

Ș.I. dr. Ing. Tripe Vidican Călin

Universitatea din Oradea, tripetrophy@yahoo.com

Keywords: mechatronics, mechatronic systems, mechatronic automobile – CAN BUS – ABS.

Abstract: in this paper, the author presents the penetration stages of mechatronics in automobiles technology, transforming them in important mechatronic products. The important equipments where mechatronics got into, meaning electronics and computer science, are informatively presented, in order to give new valences to traditional mechatronics.

1. INTRODUCTION

The concept of “mechatronics” was probably created by a Japanese engineer, introduced in 1969 by Yaskawa Electric company, in order to define the shorter way from idea to product. The concept was patented in years 1971-72 and in 1982 Yaskawa Electric company renounced to the copyrights, the concept being used on a large scale in the world.

By 1986, the concept of mechatronics penetrates also the specialty literature from Romania, characterizing industrial robots.

Mechatronics was defined as a set of synergetic components, integrated by mechanical and electronic engineering, with intelligent control of the computer, used in designing and manufacturing industrial products and processes.

From this definition results that mechatronics is an interdisciplinary field, according to figure 1.

Mechatronic systems can be divided in:

- mechatronic systems;
- mechatronic products (machines, equipments, robots, etc.)
- mechatronic vehicles;
- mechatronic precision systems;
- micromechatronic systems;

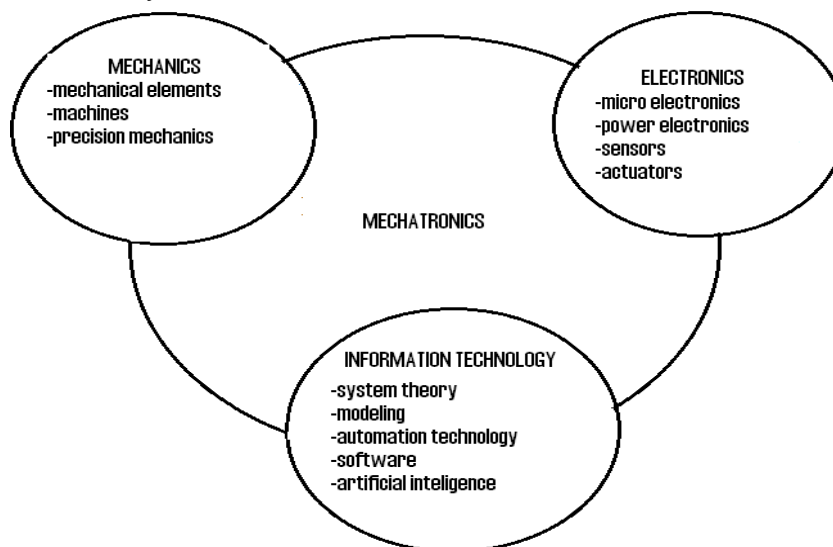

Figure.1 Synergetic integration of various disciplines Mechatronics

2. AUTOMOBILES DEVELOPMENT AS A MECHATRONIC SYSTEM

Since its appearance, the automobile revolutionized transports and concentrated the most significant scientific and engineering efforts in order to continue to improve design, but especially functional and safety performances. Until 1960, mechanical components represented an overwhelming proportion in the unity of an automobile. Electric and electronic part resumed to electric start engine (starter), battery charging systems (alternator), wipers, light and signal and lately, the radio. Weren't "safety intelligent systems". Safety belts were introduced in the early 1960s, having as a purpose to improve passengers safety and they were mechanical operated.

Automobiles engines were controlled by the driver and/or other mechanical control systems.

Electronic ignition system was one of the first mechatronic systems introduced to automobiles at the end of 1970s. Electronic ignition system consists of a crankshaft position sensor (position transducer), camshaft position sensor, airflow, position of acceleration pedal, acceleration sensors range, its property of changing the position and a micro-controller dedicated in order to determine the moment when the spark ignites.

Subsequent implementations completely eliminated the distributor and the ignition was directly controlled using a microprocessor.

After these moments, mechatronics become a necessity for differentiating the automobiles products.

In 1970s, Japanese automobiles product succeeded in fixing a bridgehead on the vehicles market from U.S.A., by the unequaled efforts regarding the quality, the consume, the functioning safety, the price and the reliability.

Nowadays, mechatronics features become products differentiators in this field.

New mechatronics applications were introduced in systems from the automobiles world including semiautomatic systems to automobiles completely autonomous, improvements regarding the emissions reduction and also other features, including its intelligent control. In figure 2 are illustratively presented the possibilities to introduce control in the systems of an automobile.

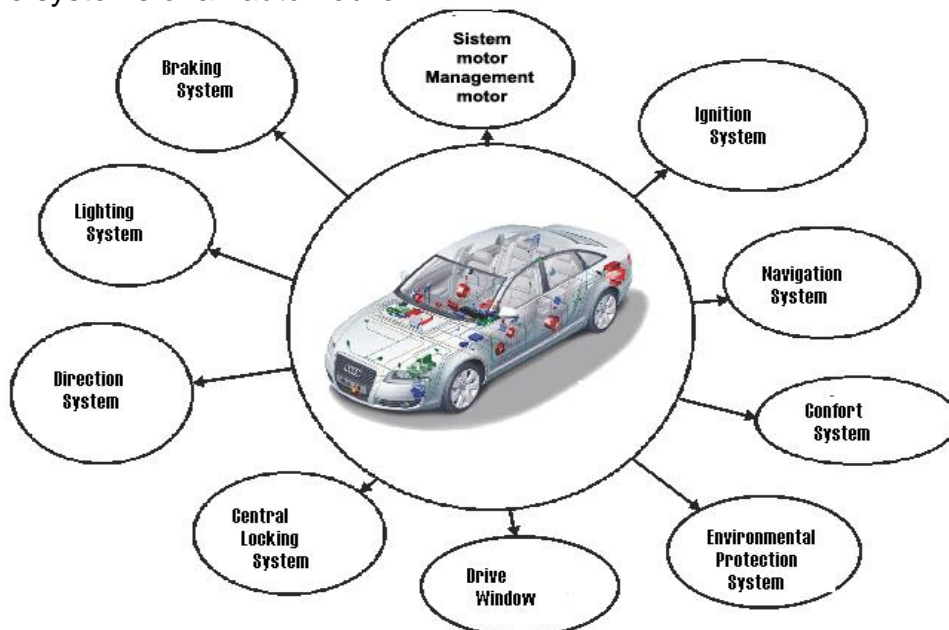

Figure 2 Possible uses of automatic control to an automobile.

We can mention that, nowadays, a modern mechatronic automobile has, in its structure between 30-70 micro-controllers, up to 100 actuators and many sensors.

3. BRAKE SYSTEM OF MECHATRONIC AUTOMOBILE

One of the most important mechatronic systems introduced in an automobile is ABS brake system (Anti-Locking Braking System).

ABS brake systems played and play a very important role in increasing active safety of the automobile, avoiding drifting to a violent braking on a greasy roadway.

Distribution scheme of ABS brake system is presented in figure 3, and in figure 4 it is shown the structure of an ABS system, on four channels.

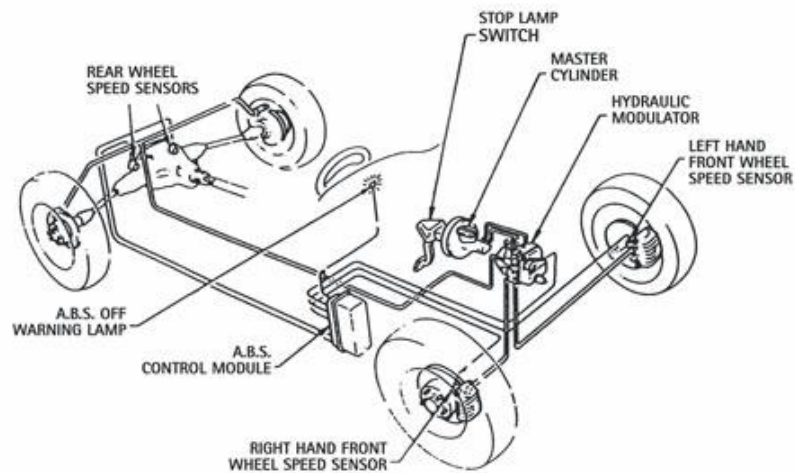

Figure 3 Distribution of ABS system components to automobiles

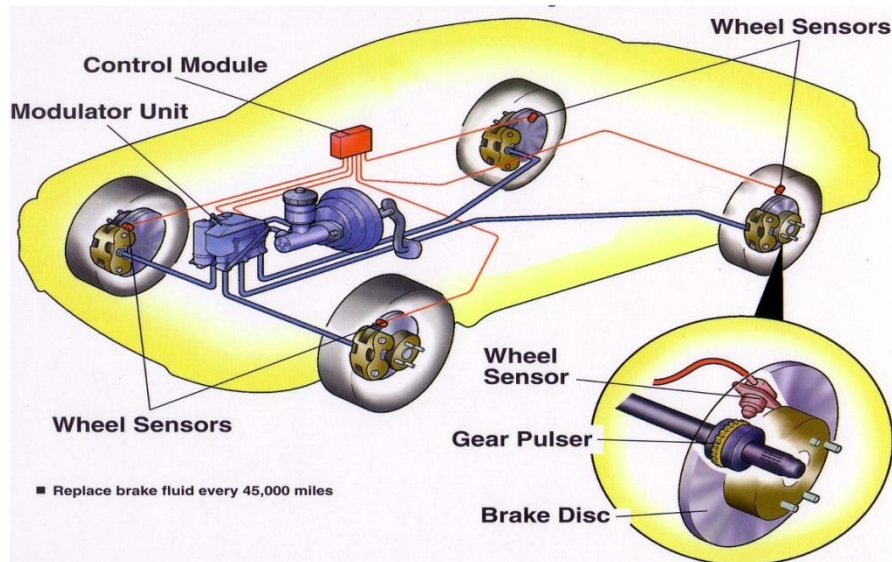

Figure 4 ABS systems on four channels

Automobiles constructors consider that one of the drastic solutions for substantial reduction of fuel consumption and of pollutant emissions is to promote hybrid propulsion systems, considered to be future solutions.

In this conception, besides the main engine, there are also engines capable to supply draft couple to the automobile's wheels and to recover a part from the kinetic energy from deceleration stages, also named regenerative hybrids.

In figure 5 is presented the block principle scheme for a mechatronic system in order to recover braking energy.

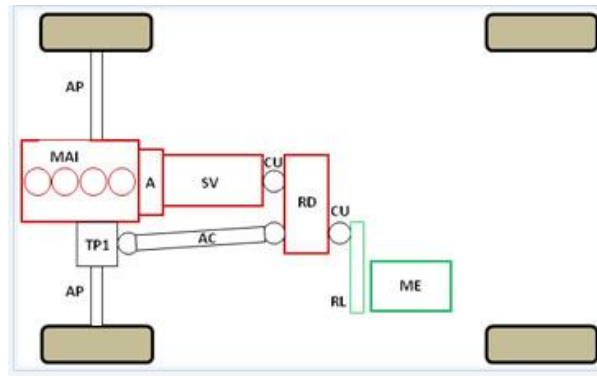

Figure 5 Block scheme of mechatronic system in order to recover braking energy.

4. ADAPTIVE ADJUSTMENT OF HEADLIGHTS

For dynamic adaptive headlights, search light beam follows the hand wheel lock starting with a road speed over 10 km/h.

In this way, during the bend, obstacles (persons, animals, etc) are faster identified by the driver and the risk of an accident decreases significantly.

Electric system proved to be the most reliable, tunings were automatized, being realized by microprocessors according to signals received from sensors. Principle scheme is presented in figure 6.

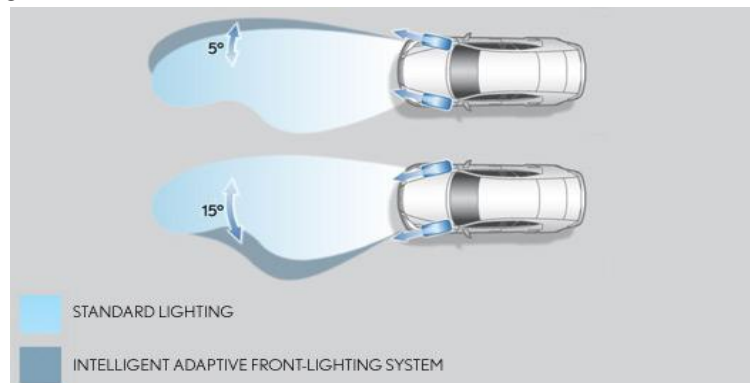

Figure 6 Scheme for automatic adjustment of headlights

5. CAN BUS – AN EXAMPLE OF SERIAL BACKBONE IN MECHATRONIC VEHICLE

CAN BUS is a digital communication system, on two lines, immune to noises and electric interferences. The computer of a modern automobile (ECU) communicates with the rest of the equipments by means of CAN BUS interference.

Several examples of equipments (devices) are engine management systems, active suspensions, ABS, gearbox control, headlights control, conditioned-air, central locking, air bags.

Block scheme of CAN BUS is shown in figure 7.

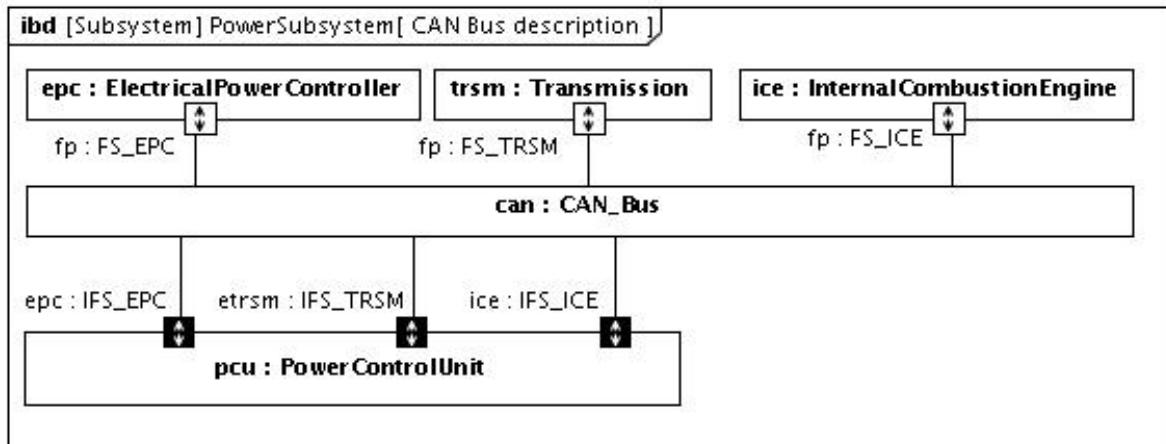

Figure 7. CAN BUS for sub-systems connection to the automobile.

Another example of significant increase that would benefit from a mechatronic approach is the creation of no lines networks in order to direct automobiles from fix stations through a communication emitter. Telematics combine audio systems, mobile phone, hands-free, Internet, navigation system, e-mail connectivity and voice recognition, probably the largest unexploited area that would be introduced in automobiles.

Radar technology is also recently found in mechatronic automobiles. The radar detect the position of the objects or other obstacles, vehicles, in a landscape, the distance until them and their speed in real time. In figure 8 is presented the block scheme of a working system with radar technology, provided by Suzuki.

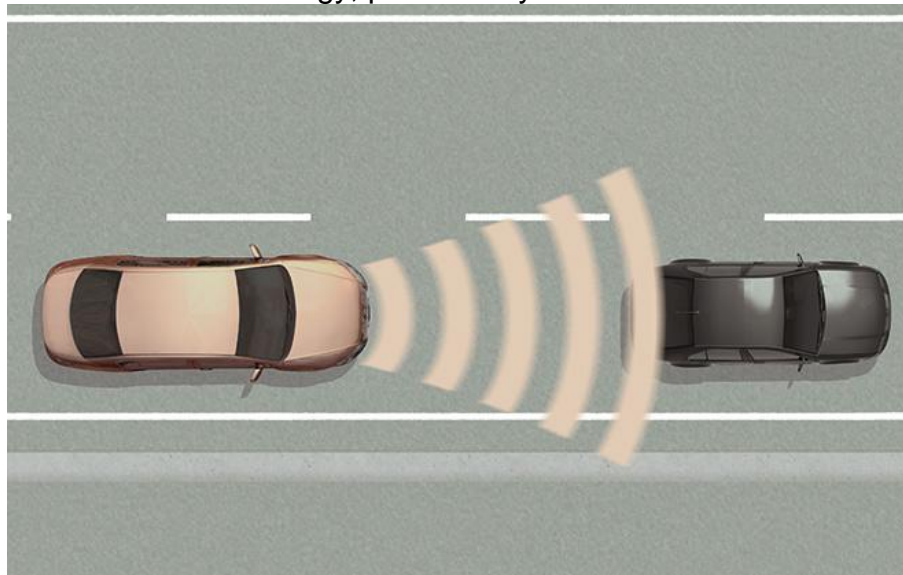

Figure 8. Radar application for measuring the distance between vehicles.

The driver can set the speed and the distance wanted towards the obstacle from the front of the car. ABS system and control system are coupled together in order to realize this capacity in safety conditions.

Researches are in progress in several research centers and companies that manufacture vehicles regarding the development of semiautomatic vehicles, planning the road to be roamed by a G.P.S. system continuously updating the traffic.

References

- [1] Asami, K ş.a. ABS-TCS-VDC. Where Will the Technology Load, I. Mack, ed.
- [2] Jorgensen, B., „Shifting gears” Auto Electronics, Electronic Business, Feb.2001.
- [3] Robert H. Bishop- Mechatronics- introduction 2006- by Taylor&France Group LLC. SUA
- [4] Society of Automotive Engineers, Warrendale PA. 1996
- [5] Tripe Vidican A.,- Sisteme mecatronice – University of Oradea, 2005.
- [6] Web Site: www.etas.com
www.manchesteruniversitypress.co.uk
<http://sc.leadix.com/mechatronics/articles>
www.aidc.co.za
www.eetimes.com/electronics-news/4072984/Mechatronics-transforms-driving-experience