

FRICITION TEST BALL ON FLAT DURING RUNNING-IN PERIOD ON UMT TRIBOMETER

Velicu Radu ¹, Lateş Mihai ¹, Papuc Radu ¹
Transilvania University of Braşov
rvelicu@unitbv.ro

Keyword: tribometer, friction, friction coefficient, testing, joint, tribology

Abstract: This paper presents results of friction tests made during running in period for a tribosystem with ball on flat contact with sliding, under dry or boundary/mixed friction. Linear movement between triboelements is obtained in two ways: rotation of a disk and respectively translation on fixed plate. The experiments have pursued two objectives: determine the friction forces and friction coefficients for different friction conditions; determine the measured wear or the surface topology of the friction surfaces, for different friction conditions and surface precision.

1. INTRODUCTION

Depending on the type of relative movements, different types of friction joints are defined [1, 2, 3, 4, 5, 6]: movement with slip (fig.1 – a); movement with rolling (fig.1 –c); movement with spin (fig.1 –b); impact movement (fig.1 –d). This paper reefers to the movement with slip. At any friction joint (tribosystem) four features can are distinguished (fig.2): triboelements (1-2), the intermediate element (3) and the environment (4).

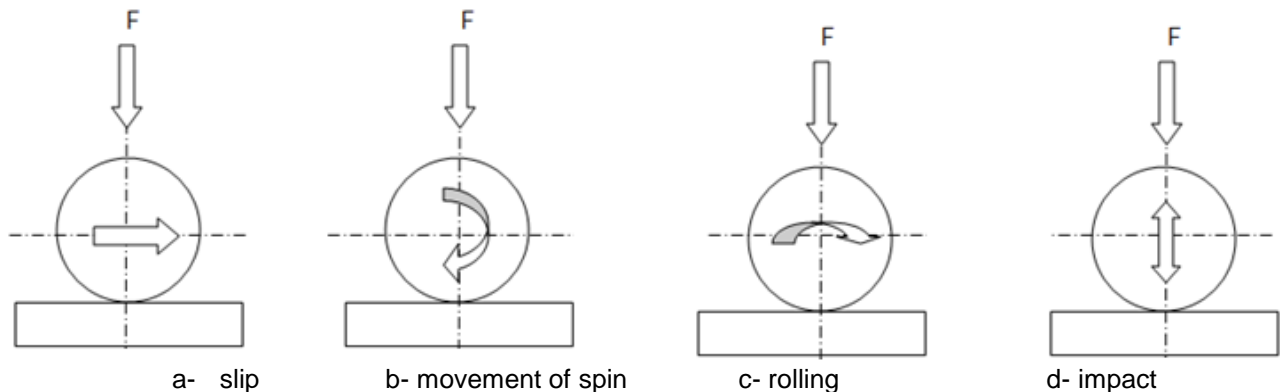

Fig. 1. Types of friction joints

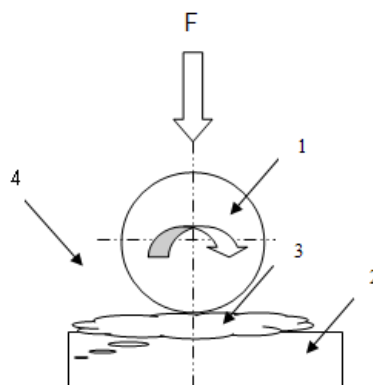

Fig. 2. The structure of a tribosystem

The following must be considered in order to define the friction joint [1, 3]: transmitted load – F ; the relative speed between the triboelements – v ; the nature of

triboelements, intermediate element and environment. The way of transmitting the force from an element to another is determined by the geometry of the two triboelements that consist the joint:

- The friction joint with the contact on planar surface, cylindrical surface, conical surface, or spherical surface;
 - The friction joint nonconforming with the contact on elliptic surface or linear type.
- The transmitted force from an element to another is acting on a contact area. Three surfaces [2, 3] can be defined (fig. 3):

- The apparent surface of contact X_1 ;
- The real surface of contact X_2 ;
- The nominal surface of contact X_3 .

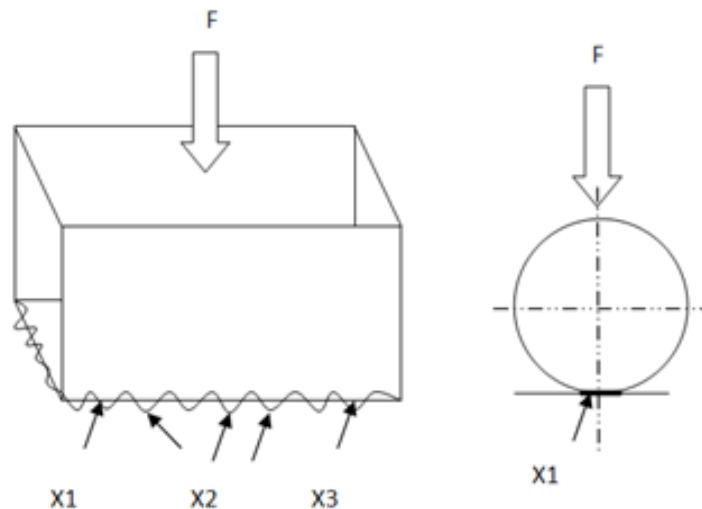

Fig. 3. Contact surfaces

The intermediate element of contact may be solid or fluid. The thickness of lubricant film between the bodies is dependent of parameters of tribosystem, such as:

- The geometry of construction solution and the position of bodies;
- The topographies of surface of bodies in contact;
- The relative speed between the bodies in contact;
- The outside charges;
- The viscosity of lubricant;
- The temperature.

The contact between the bodies can be characterized in according with the film thickness of lubricant. Table 1 presents the friction regimes of any tribosystem and the friction conditions that determines them.

The running in period of any tribosystem is characterized by important changes in: the topology of contact surface, wear and value of the friction force.

This paper is presenting the results of friction tests made during running in period for a tribosystem with ball on flat contact with sliding, under dry or boundary/mixed friction. Linear movement between triboelements is obtained in two ways.

Table1. The friction regimes between the bodies in contact

The frictions regimes	The friction condition
Dry friction	No lubricant

Boundary friction	The limited superficial layers, resulted by oxidation, by absorption and/or chemo absorption of the favorable molecules of friction decrease
Mixed friction	The partial film of fluid and direct contact between the bodies
Fluid friction	The completed separation by fluid film (elastohydrodynamic, hydrodynamic)

2. FRICTION TEST ON UMT TRIBOMETER. CONCLUSION

The testing was made on the UMT3 [7] tribometer, an equipment that can measure friction force, static and dynamic coefficients of friction and wear in different conditions of lubrication, for rotational or translational movement with different speed, for different types of contact, for different normal forces.

The experiments have pursued two objectives:

- Determine the friction forces and friction coefficients for different friction conditions;
- Determine the measured wear on the friction surfaces, for different friction conditions and surface precision.

The objectives must also cover the changing the direction of movement between triboelements.

The two tested triboelements are:

- 12 mm diameter ball, hardened steel (61 HRC), roughness $R_a = 0.4 \mu\text{m}$;
- disk/plate, mild steel (39 HRC), roughness $R_a = 1.6 \mu\text{m}$.

2.1. BALL ON DISK BOUNDARY/MIXED FRICTION TEST

The ball is placed eccentric at a radius $r = 25 \text{ mm}$ and pushed against a 70 mm rotating disk. An image of the ball on disk module of UMT tribometer is shown in fig. 4.

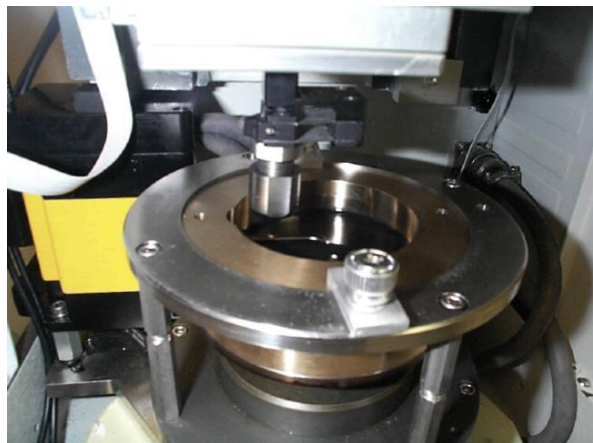

Fig. 4. Ball on disk UMT module

The module is consisted of an rotating unit, a support special lubricated with protective cover against oil spills, a ball holder, ball, lubricant in bath. The lubricant used is an 5W30GM motor oil and the testing temperature is 20°C.

The following parameters are used for testing: down force 50N; rotation speed 1000 rpm/min; time 20min; 5 min. cycles with reversed rotation.

The running-in of the disk surface is studied in order to obtain the variation in time of friction coefficient and also the wear of surface (the disk surface is the one with higher roughness and lower hardness, predisposed to the effect of wear).

Figure 5 presents the variation of the coefficient of friction (COF) with time. The friction coefficient is calculated as the absolute value of the ratio between the measured friction force and the measured normal force (down force).

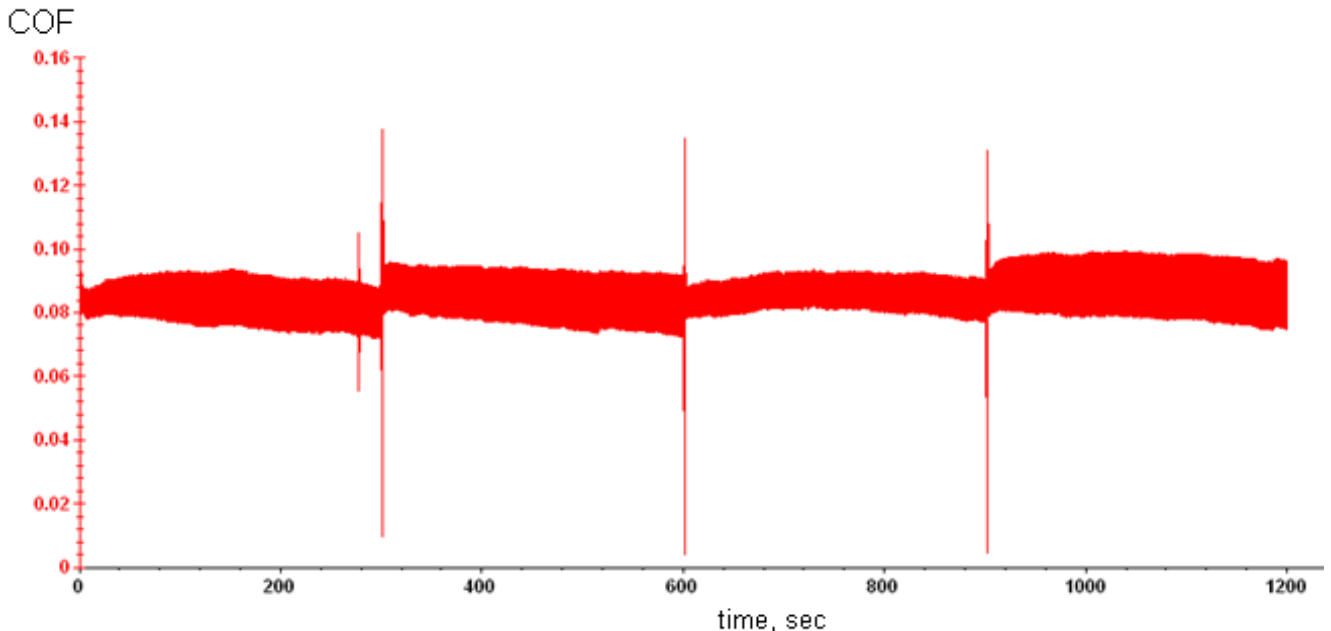

Fig. 5. Friction coefficient (COF) variation with time

The following conclusions can be drawn on the results presented in fig. 5:

- The variation of the friction coefficient covers a range of $\pm 10\%$, which is very large and far from a good precision; It can be explained by the continuous automatic control of the down force, together with the bad accuracy of the running in surfaces.
- The leap on the value of friction coefficient at the change of rotation direction is explained by the dynamic process and the change of sign of the measured friction force.

Since the automatic control of the down force moves the ball and its holder down to the surface of the disk, the wear can be appreciated by vertical displacement of the ball.

Figure 6 presents the variation with time of the vertical position of the ball (ball holder) Z, measured in mm.

Variation of ball position helps in drawing the following conclusions:

- Non-planar path of contact along the rotating disk – during one rotation of the disk an approximately $1 \mu\text{m}$ amplitude cyclic displacement can be observed;
- The leap of the position Z at the change of direction of rotation can be explained by the existing clearance in the automatic control of the down force – the measured value of Z position should continue where it was left at the end of the previous cycle; in this case the total displacement is approximately the scale of the Z position ($84.512 - 84.496 = 0.016 \text{ mm}$);
- The relatively large displacement of the ball relative to the disk is not just wear, being explained also by the change of the real surface of contact.

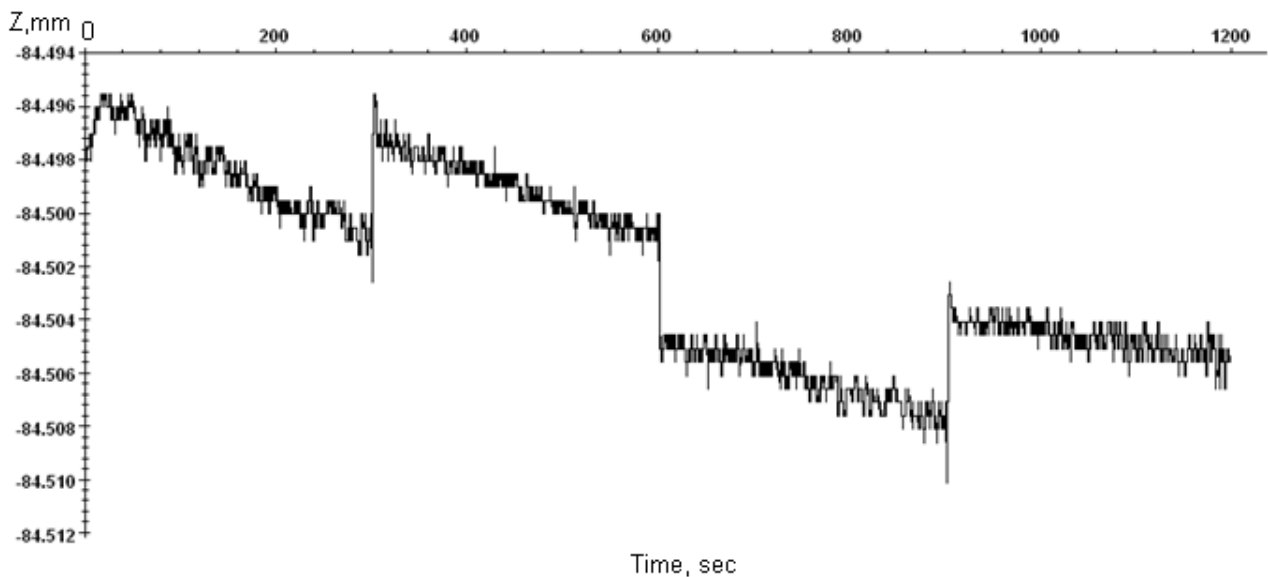

Fig. 6. Variation with time of the vertical position of the ball

2.2. BALL ON PLATE DRY FRICTION TEST

The ball is placed on a fixed plate. The ball is translated by the upper actuator along the plate. The conditions of testing are: dry friction (no lubrication); down force 20N; velocity 0.25 mm/sec; 2 cycles of 10 mm reversed translation, 20°C temperature.

Figure 7 presents the variation of the coefficient of friction (COF) with time.

The following conclusions can be drawn on the results presented in fig. 5:

- The variation of the friction coefficient covers a range of $\pm 10\%$, which is very large and far from a good precision;
- The variation is following a pattern, which means that the topology of the surface is determining the friction; the same peaks appear during forward and backward movements for the same positions indicating the deep influence of the surface topology;
- The leap on the value of friction coefficient at the change of direction of movement is explained by the dynamic process and the change of sign of the measured friction force.

Figure 8 presents the variation with time of the vertical position of the ball (ball holder) Z, measured in mm. In this case the variation of vertical position of ball has the following meaning:

- The path of translations follows a line with approximately 25 μm deviation from horizontal line (down and then up), coming from surface topology;
- The diagram shows the topology of the surface but inside this variation, the roughness is less visible but still clear;
- The leap of the position Z at the change of direction of rotation can be explained by the existing clearance in the automatic control of the down force.

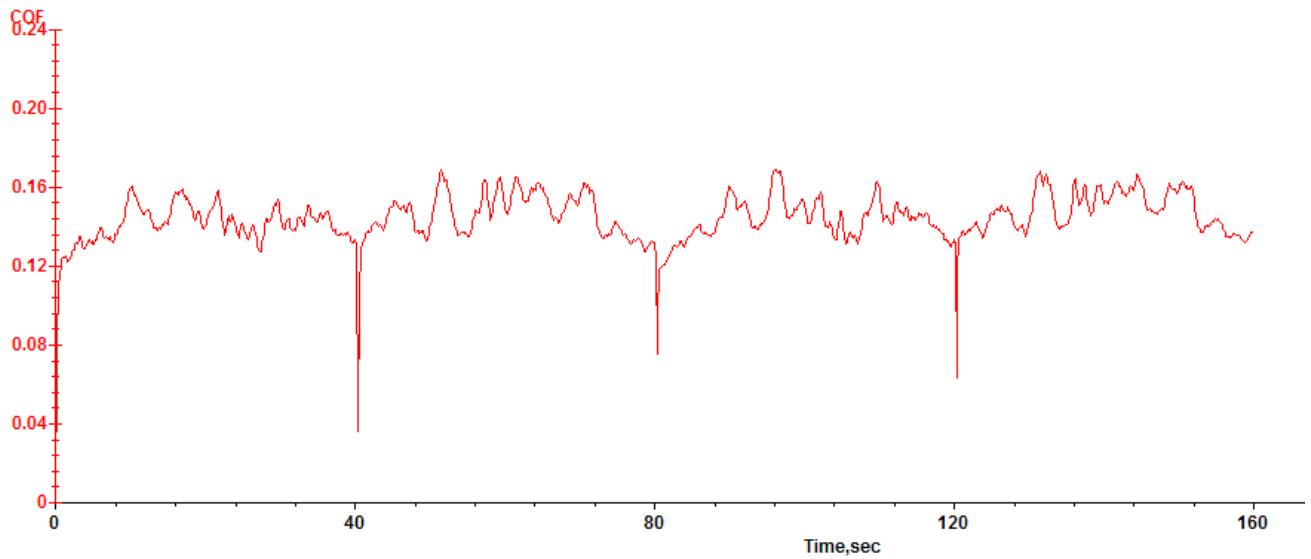

Fig. 7. Friction coefficient (COF) variation with time

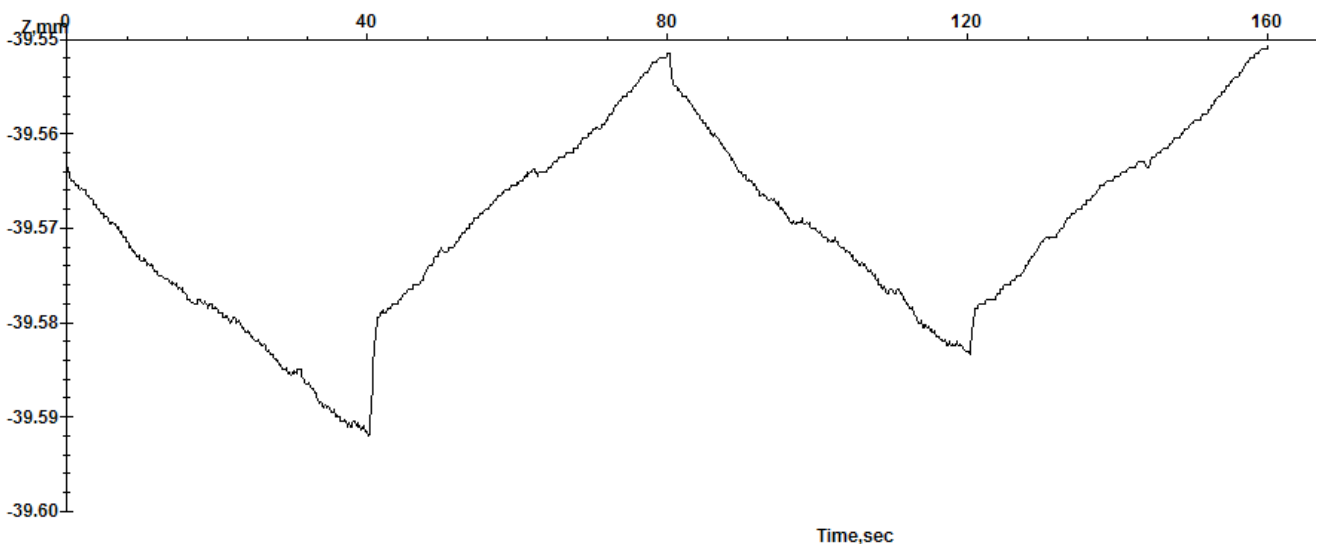

Fig. 8. Variation with time of the vertical position of the ball

References:

1. S. Bobancu, R. Cozma, Tribology (in Romanian), Ed. Universitatii Transilvania, Brasov, 1995.
2. R. Cozma. Fundamentals of tribology (in Romanian), Ed. Matrix Rom, Bucuresti, 2011, ISBN 973-685-861-8
3. M. Gafitanu s.a, Machine Elements (in Romanian), Ed. Tehnica, Bucuresti, 1983, ISBN 973-31-1400-6
4. D. Pavelescu s.a, Tribology (in Romanian), Ed. Didactica si Pedagogica, Bucuresti, 1977.
5. A. Jula, a.o., Machine elements, Vol. 2 (in Romanian), Ed. Universitatii din Brasov, 1989.
6. A. Jula, E Chisu, M. Lates, Mechanical transmissions (in Romanian), Ed. Universitatii Transilvania, Brasov, 2005, ISBN 973-635-444-1
7. *** CETR UMT Multi-Specimen Test System Hardware Installation & Applications Manual, Centre for Tribology, USA, 2009.