

# CONTRIBUTIONS TO THE DIVERSIFICATION OF FOOTWEAR SOLES FOR DIRECT SOLING INJECTION USING MOULDS WITH INTERCHANGEABLE PARTS

Cozmin IONESCU<sup>1</sup>, Cornelia LUCA<sup>2</sup>, Bogdan SÂRGHIE<sup>3</sup>

<sup>1</sup>“Gheorghe Asachi” Technical University of Iasi-Romania, e-mail: cionescu@tex.tuiasi.ro

<sup>2</sup>“Gheorghe Asachi” Technical University of Iasi-Romania, e-mail: cornelialuca@yahoo.com

<sup>3</sup>“Gheorghe Asachi” Technical University of Iasi-Romania, e-mail: bogdan.sarghie@ymail.com

**Abstract**— One solution for attaching soles on footwear is to inject them directly into the upper part using moulds with unique cavities. Injection moulds are manufactured for each sole design, for each foot, right and left, and for each size number. As a result of the market demand for a large number of soles designs, the execution costs of moulds for each of them are substantial. In the case of small manufacturers, injection moulds wear out morally long before they wear out physically. This paper will present some design solutions for moulds that have reusable parts that can be used from one sole design to another, without changing the entire mould. Using these moulds, soles design can be modified by interchanging some modules which are fitted into the main mould cavities. These solutions represent a cheaper and faster alternative for classic moulds, with unique single cavities.

**Keywords**— footwear, injection moulds, moulds design

## I. INTRODUCTION

Shoe soles injected directly on footwear uppers are manufactured using moulds with unique cavities. Injection moulds are manufactured for each sole design and for each size number. Soles have become increasingly more a way for footwear design diversification. For this reason, it is necessary to manufacture a wide variety of injection moulds, for each sole design. Using an injection mould, approximately 200000 pairs of soles can be made until it wears out [1]. For small manufacturers this production capacity is too high, being forced to replace moulds not because of their physical wear, but because of their technical obsolescence. In this case, moulds are used a limited number of cycles and after that are stored in a warehouse or are melted to make new moulds, which implies higher exploitation costs. Due to moulds complex manufacturing process, time-consuming and expensive,

their exploitation is not profitable lower than their designed production capacity [2], [3].

The authors have developed design solutions [4], [5] for sole injection moulds with parts that can be interchanged, depending on the sole design. For a new sole design, it will not be necessary to change the entire mould, but only some components. Moulds developed by authors have been referred as of “injection moulds with interchangeable modular cavities for soles attached directly on footwear upper part”.

## II. DESIGN SOLUTIONS DEVELOPMENT

The development process of the solutions for injection moulds had in consideration the possibility to manufacture a wide range of footwear soles designs and with lower costs [4]. At the same time, it was considered that the designed moulds to have similar functional characteristics with those of moulds with single cavities, regarding: the assembly onto injection machines, operating mode of the mechanisms for opening and closing the moulds, the possibility to adjust the technological parameters of the injection process, and so on. These restrictions took into consideration the exploitation possibilities of such moulds on existing injection machines, without further adjustments.

### A. Solution 1

Single cavity injection moulds for attaching soles directly on footwear uppers are composed of a metallic last, two side tanks and punch, which enclose a unique cavity in which the sole is manufactured.

This paper presents a solution for restructuring classic moulds [4] in order to be possible to reuse all components or some components from the injection mould when changing the sole design. The drawings

from Fig. 1., represent such a solution. In this case, the mould cavity is the result of the closure of the following components: two interchangeable modules 4 and 5 which are fitted on the two tanks, one interchangeable module 6 which is fitted on the punch and the metallic last on which the footwear uppers last. Using these moulds, by

interchanging its modules it is possible to change the sole design partially by changing the lateral sole surface design and the antiskid embossment design. The shape and volume of the sole remain the same from one design to another.

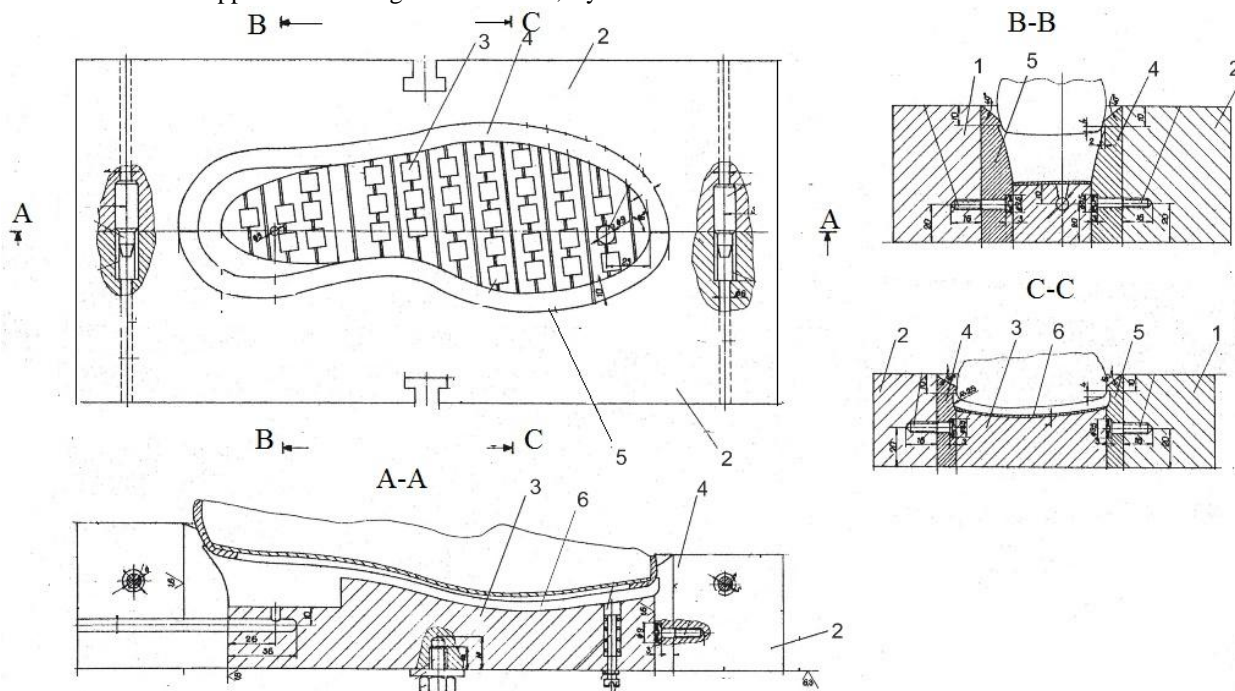

Fig. 1. Modular mould for direct soling injection. Solution 1.

- 1- exterior tank; 2 interior tank; 3- punch; 4- interior tank cavity forming a module; 5- exterior tank cavity forming a module; 6- antiskid embossment design module; 17- metallic last.

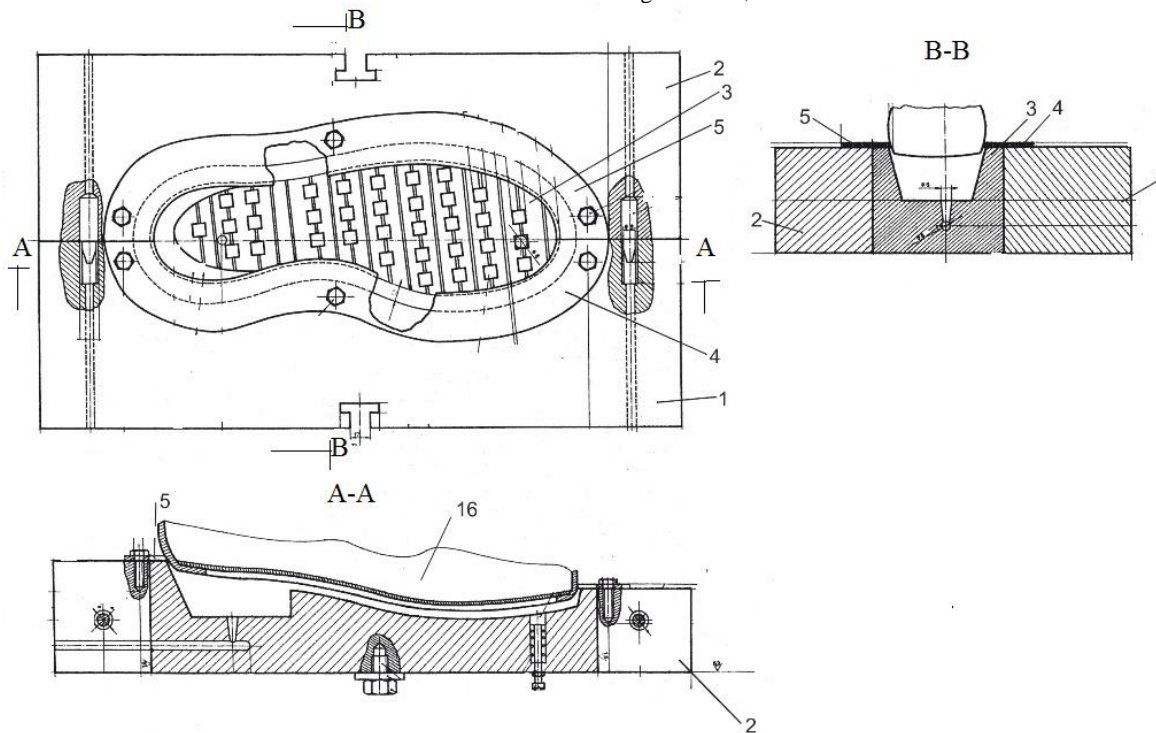

Fig. 2. Modular mould for direct soling injection. Solution 2.

- 1- interior tank; 2- exterior tank; 3- cavity forming a module; 4- feathering design interior module; 5- feathering design exterior module; 16- metallic last.

### B. Solution 2

Another solution for restructuring classic moulds for injecting soles directly on footwear uppers [4] is presented in Fig. 2.

Through this solution, the sole cavity is formed by closing the following mould components: the metallic last on which footwear uppers last, the cavity forming module, part number 3 that substitutes the punching part from classic moulds and the modules responsible for the feather line design, respectively parts 4 and 5.

Each time when the shape and volume of soles are changed, it is necessary to change all sole cavity modules. If for a new sole design, the feathering design remains the same, the associated modules will be reused.

For both solutions the following components are reused: lateral tanks, metallic last, mechanisms for fitting the mould into the injection machines, closing/opening components, feeding systems and so on.

As in the case of single cavity moulds, this new moulds are also made for each leg, left and right, and for each footwear size number.

## III. EXPERIMENTS

Based on proposed solutions for the injection moulds design, prototypes of these moulds were made and were tested by manufacturing soles.

### A. Experimental mould for Solution 1

The reusable parts of this modular injection mould are the following: the metallic last on which footwear uppers last, which is the same as the one used for moulds with unique single cavities; two lateral tanks on which the modules that define the lateral sole surface design will be fitted, and the punch on which the modules that define the antiskid embossment design will be fitted.

Using this modular injection mould, limitless sole designs can be made by interchanging modules that determine the design of the lateral sole surface and of the antiskid embossment [6], [7].

The shape and volume of soles remain the same. Experimental mould is presented in Fig. 3.

The soles with different designs, obtained using the experimental mould by interchanging various modules, are presented in Fig. 4.

### B Experimental mould for Solution 2

For this solution, the injection mould parts that will be reused for new soles designs until they wear out are the following: the metallic last, the two lateral tanks and one bearing plate used for fitting the moulds on injection machines. The metallic last is similar to that used for single cavity moulds and has the shape and size of the shoe lasts on which the footwear uppers lasted. The overall dimensions of lateral tanks and of the part used for fitting the modules are the same for all size numbers,

differences arise from one size number to another for the openings for fitting the interchangeable modules.

Therefore, for this type of moulds, varies only the dimensions of the interchangeable modules that determine the shape, volume and antiskid embossment of soles. This parts will be manufactured for each leg, left and right, and for each size number, each time when the sole design is changed. Also, for these moulds, the modules that determine the shape and volume of soles will be designed such that will allow other modules that determine the antiskid embossment design to be fitted in their cavity.

In the framework of conducted experiments, several interchangeable modules were manufactured and were used with an injection mould to manufacture soles with various designs [4], [8].

The injection mould, the reusable parts, the interchangeable modules and the manufactured footwear soles to which have been made are presented in Fig. 5.



Fig. 3. Modular mould for direct soling injection. Solution 1.



Fig. 4. Soles injected using a modular mould. Solution 1.



Fig. 5. Modular mould for direct soling injection. Solution 2.

#### IV. CONCLUSIONS

- 1) *The design solutions for injection moulds proposed in this paper allow construction of new sets of moulds faster and cheaper. This is determined by the way these moulds are structured, which makes it possible to reuse until physical wear parts from old injection moulds for new moulds.*
- 2) *Solution 1 allows various sole design diversifications by changing the lateral sole surface design and the antiskid embossment design, but only for soles with the same size, shape and volume. Solution 2, compared with solution 1, allows changes in shape and volume of soles.*
- 3) *Experiments have shown that for both proposed solution, moulds time and costs can be reduced by 20% and 80% compared with classic injection moulds, with unique single cavities. The fewer modules are rebuilt, costs for manufacturing new moulds are smaller. The costs economy is even higher when manufacturing moulds for the entire size set. This fact will allow faster launch on the market of new soles lower and with lower prices.*
- 4) *By manufacturing a few moulds with interchangeable modular cavities, compared with classic ones, various sole designs can be made very fast, which allows time for market research purposes. Therefore, such type of injection mould facilitates the process of designing and prototyping footwear soles. Also, these types of moulds are suitable for research activities regarding new polymer recipes.*
- 5) *Injection moulds manufactured through proposed solutions, have the same functional characteristics*

*as classic moulds, with single unique cavities and can be operated on the same injection machines, without any modifications.*

- 6) *The use of such moulds is profitable, compared with classic moulds, for small companies. Using the manufacturing process of soles, this new moulds, with interchangeable modular cavities, opens new perspectives in the field.*

#### REFERENCES

- [1] R. McNeel, "Shoe Design and Visualization", Institute of Biomechanics of Valencia, Rhinoceros Advanced Training Series, Available: [https://anna.nscad.ns.ca/help/pdfs/rhino\\_shoe.pdf](https://anna.nscad.ns.ca/help/pdfs/rhino_shoe.pdf), Accessed:20/February/2016.
- [2] L. Mărcuș, "Regarding the Lasting of Footwear Uppers Using Different Technological Variants", in *Annals of the Oradea University, Fascicle of Textile Leatherwork*, 2008, pp. 331-336.
- [3] M. Drișcu, "Modelling of Planar and Spatial Forms of Footwear", in Romanian, *Pim Press Iași*, 2008, pp.109-134.
- [4] C. Ionescu, R. Mocanu, I. Cioară, "Obtaining modular cavities in moulds used forming soles directly on the footwear" in *Proceedings Autex 2015, 15th World Textile Conference*, Bucharest, Romania, 2015, ID 162
- [5] M. Costea, "Footwear and rapid prototyping modelling components prophylactic", *Publisher Performantica*, 2015, ISBN 978-606-685-328-6, pp. 80-97.
- [6] E. Chirilă, "Solutions on aspects for mathematical modelling of the optimum number of the nests that a cast must have", in *Bulletin I.P.Iași, Tome LIV (LVIII), Fasc. 1-3 Mechanical Engineering Department*, Romania, 2008, pp.125-129.
- [7] A. Dragomir, "Emplacement possibilities of the cavities and some positioning possibilities of the injection channels in the moulds used footwear manufacturing", in *Proceedings "The X International Conference on the Theory of Machines and Mechanism"*, Technical University of Liberec, sept. 2-4, Czech Republic, 2008, pp. 189-193.
- [8] M. Costea, A. Mihai, "The structure and design of footwear", *Publisher Performantica*, 2015, ISBN 978-606-685-328-6, pp 125-142