

From Design to Motion: Kinematic Modeling and 3D Simulation of Industrial Robots

Y Elkamshoushy¹, Gy Korsoveczki¹

¹Electrical Engineering and Mechatronics Department, Faculty of Engineering, University of Debrecen, Debrecen, Hungary

yara.elkamshoushy@gmail.com, korsoveczki.gyula@eng.unideb.hu

Abstract. In this paper, we will discuss the topic of the kinematics and modeling of industrial robots. Modeling industrial robots plays a significant role in modern manufacturing and automation. We will also delve into the kinematics calculations of forward kinematics (FK) and inverse kinematics (IK) in this paper, as well as how to compute them and what the difference between them is. We will also propose a 3D model done, using Autodesk Inventor, of a robot with its respective printed circuit board (PCB) carefully designed, using KiCAD, to match the robot's requirements. Furthermore, with an increasing demand for precision, flexibility, and efficiency, models of robotic systems are essential for optimizing performance and ensuring reliability. Generally, industrial robots are complex with multiple degrees of freedom systems that require precision control. Hence the importance of modeling a robot is very important and is one of the most important steps in robot design.

1. Introduction

Virtual design of robots has become an important factor in modern industrial robotics. It refers to the process of creating detailed, accurate 3D models and simulations of robots before they are physically built. This approach allows engineers to evaluate the stress, performance, control strategies, and the kinematics of a robot prior to manufacturing in a virtual environment. Thus, making it easier to identify and solve design issues early in the development process. Moreover, virtual design is especially important due to the high demand for precision, reliability, and efficiency in manufacturing processes. By leveraging both KiCAD and Autodesk Inventor, we can be able to simulate real-world tasks without the need for costly and time-consuming physical prototypes.

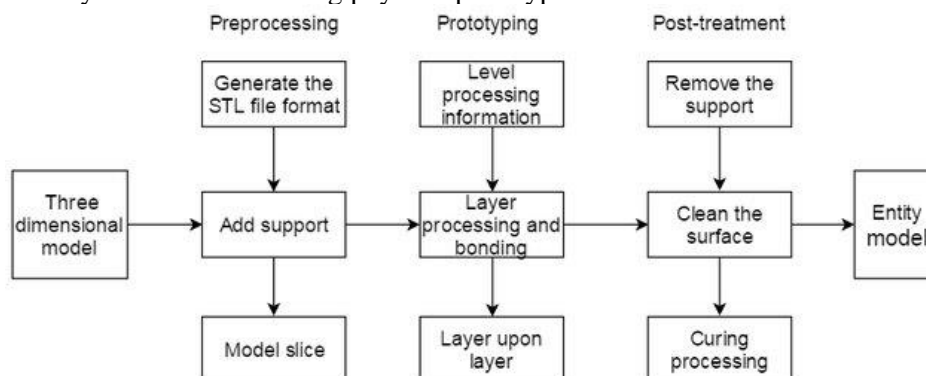

Figure 1. Process of 3D model to entity flow chart [1]

As seen in *Figure 1*, the process from having a 3D model to finally an entity model is strictly consecutive and there is no way to undo the process. However, prior to preprocessing, it is possible to make modifications to the 3D model. This is a great advantage since it enhances the flexibility and adaptability in industrial robots. As industries continue to evolve and require more versatile robotic systems, the more engineers get to test different configurations, trajectories, and control algorithms. Hence, ensuring that robots perform in diverse and dynamic environments.

2. Kinematics

Regardless of the application of a robot, the ultimate goal of any robotic system is achieved through its motion understanding (kinematics) [2]. Kinematics is the study of motion relative to all the linkages of a robot [3]. Forward kinematics (FK) and inverse kinematics (IK) are fundamental concept in robotics that determine how robotic arms move and interact with their environments.

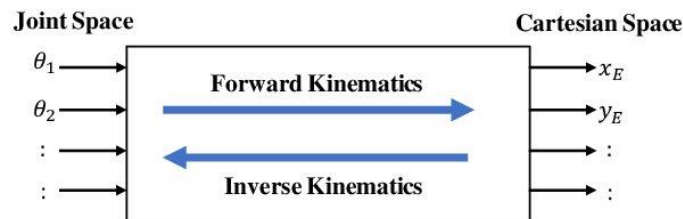

Figure 2. Forward and inverse kinematics difference [4]

The major difference between FK and IK seen in *Figure 2*, is that FK computes the position and orientation when joint angles and actuator lengths are given. However, IK finds the joint angles when the position and orientation are given [5]. In other words, the difference between them is the direction in which the computation is occurring. Meaning that each direction generates a solution: Cartesian space, also known as the world coordinates, to Joint space (IK), or vice versa (FK).

2.1. Forward Kinematics

FK calculations are very straightforward and direct. The main concept of is to compute the kinematic linkages through the length of the linkages and the joint angles given. To do so, we use the Denavit-Hartenberg (DH) parameters.

1. Denavit-Haternberg parameters

DH parameters help us with both kinematic calculations. These parameters help us to form the homogenous transformation matrix that aids us compute the kinematic calculations. They are first assigned to each joint, and each joint consists of 4 parameters associated with a manner for attaching reference frames to links of a spatial kinematic chain [6] [7]:

2. d : offset from the center of the previous joint to the center of the current joint measured from Z_{i-1} .
3. θ : angle needed to rotate the joint around Z_{i-1} until axis x_{i-1} is aligned to x_i .
4. a : offset from center of the previous joint to the center of the current joint measured from x_i axis.
5. α : angle needed to rotate the joint around x_i axis until axis Z_i is aligned to Z_{i-1} .

2.2. Inverse Kinematics

IK is far more difficult than FK for many reasons including the fact that there are many possible outcomes for an IK solution as compared to FK which has a single, direct solution. However, there are a multitude of methods to use to obtain an IK solution which include analytical and numerical. The analytical approach is much faster and real-time capable as compared to the numerical, in addition, the analytical method involves solving the first 3 rotary joints IK problem in closed-form expressions

based on the structure of the robotic arm [9] [10]. Most numerical IK solution methods use the Newton-Raphson algorithm or a similar algorithm to iterate until they find a solution [11]. Steps for the Newton-Raphson method involve initialization, calculation, obtaining a new valuation, and continuing the iteration and generating new joint angle values [12].

3. Design principles

This chapter focuses on the design and development of the 3D model of a robot including the key principles and parameters that guide its development. We will explore the maximum range of workspace and structural components. Additionally, this chapter outlines the step-by-step process in which the model and assembly of the robot has been created. Moreover, we will also cover the topic and decision making upon the PCB that was made to fit the robot's needs. Through this, the foundational elements of the robot's 3D model will be clearly defined, laying the groundwork for its real-world implementation.

3.1. 3D design of robot

The first steps that need to be taken into consideration when designing a robot are the robot type, degrees of freedom, and finally the workspace. Furthermore, we decide afterwards the components necessary to assemble the robot.

3.1.1. Components

After deciding on the robot type, the components had to be designed separately before assembling them altogether.

3.1.2. Exploded View

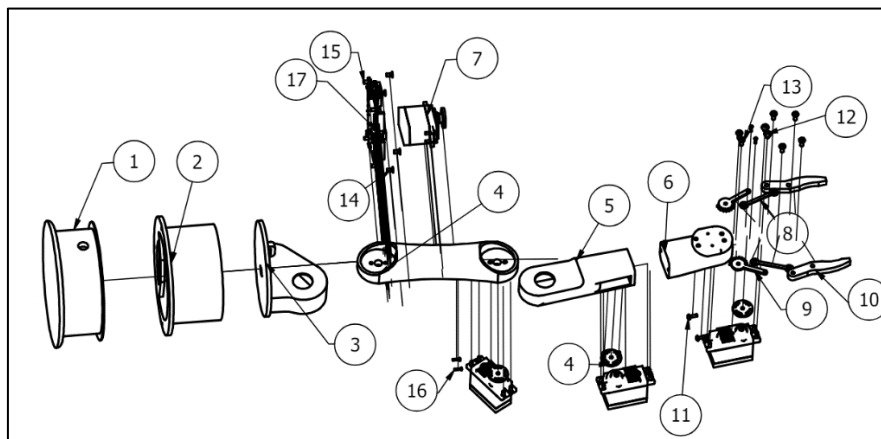

Figure 3. Exploded View of robotic arm assembly [done by author]

3.2. Printed Circuit Board

The PCB serves as a center for the robot's control system, connecting its sensors, actuators, and power components. In this section, we will explore the design principles behind the PCB we developed for this robot, focusing on its layout and component selection. The PCB plays a crucial role in executing precise movements and coordinating feedback from sensors, making its design a critical aspect of the overall robotic system. Making sure the performance is optimal to meet the specific requirements of this project. The PCB's main design included an ATmega328P based controller to control the robotic arm, used a CH340G USB-UART converter that allowed for communication and programmability via USB. Moreover, it also included an ISP programming port (standard AVR 2x3 pin connector). The circuit also

had 2 power inputs (an external: power connector and an internal: USB), which had to be disconnected from one another so that only one of them supplies power to the microcontroller at a time.

3.2.1. Schematic

The schematic of the PCB can be seen in *Figure 4*. After creating the schematic and running all electric rule checkers, we head onto the footprint assignments where we decide the dimensions, sizes, and manner in which all components will look on the PCB.

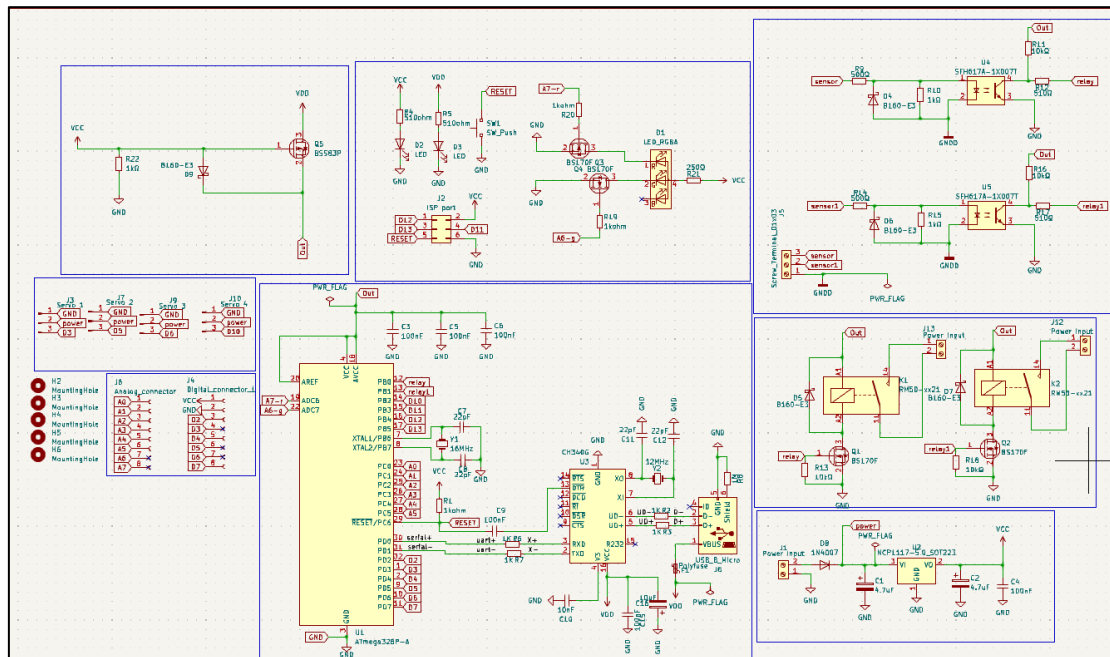

Figure 4. Schematic of the PCB [done by author]

We then finally begin with the final step which is wiring the PCB which can be seen in *Figure 5*. While wiring, some challenges were faced due to many rules being applied to components such as galvanic isolation, polarity protection, differential routing, avoiding too many wires from crossing the crystal, thickening wires due to too much power going through the wires, and avoiding too many wires crossing the microcontroller.

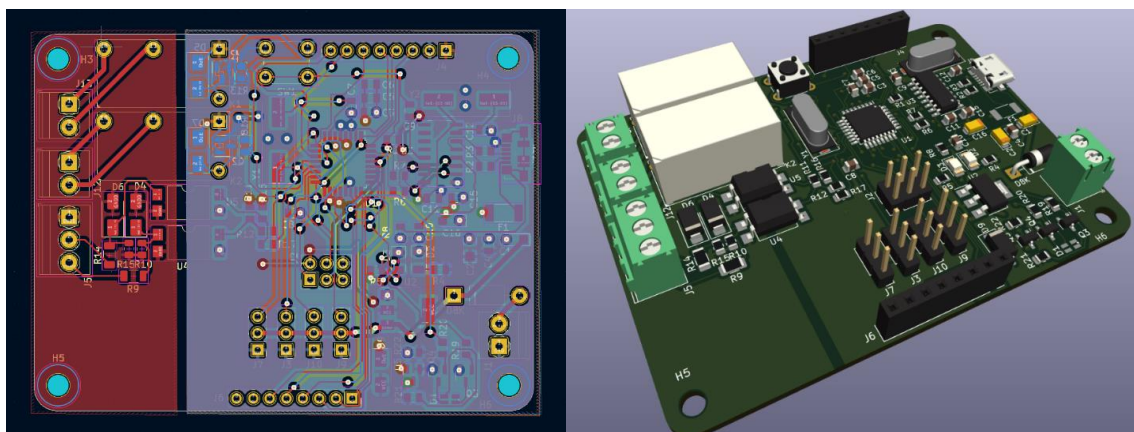

Figure 5. PCB board editor [done by author]

4. Summary

This paper has outlined the complete process of creating a 3D model of an industrial robot, from conceptual design to a virtual assembly. It begins by establishing the robot's design requirements.

Afterwards, the model was developed using Autodesk Inventor, with attention to joint configurations and the integration of a personalized PCB. Kinematic analysis and simulations were conducted to ensure precise movement, addressing both forward and inverse kinematics. The virtual testing verified the robot's free movement without restrictions, with final adjustments made to optimize functionality. These steps provide a comprehensive guide for transitioning the virtual model into future physical prototyping.

5. References

- [1] B. Hao and G. Lin, "3D Printing Technology and Its Application in Industrial Manufacturing," *IOP Conference Series Materials Science and Engineering*, vol. 782, no. 2, p. 022065, Mar. 2020, doi: 10.1088/1757-899x/782/2/022065. Available: <https://doi.org/10.1088/1757-899x/782/2/022065>
- [2] U. Dey and K. C. S, "A web-based integrated GUI for 3D modeling, kinematic study, and control of robotic manipulators," *Computer Applications in Engineering Education*, vol. 28, no. 4, pp. 1028–1040, Jun. 2020, doi: 10.1002/cae.22282. Available: <https://doi.org/10.1002/cae.22282>
- [3] T. P. Valayil and R. S. Augustine, "Methods to solve forward kinematics of parallel and serial manipulators," *AIP Conference Proceedings*, Jan. 2022, doi: 10.1063/5.0115314.
- [4] N. Sharkawy, "Forward and inverse kinematics solution of a robotic manipulator using a multilayer feedforward neural network," *Journal of Mechanical and Energy Engineering*, no. Online First, Oct. 2022, doi: 10.30464/jmee.00300. Available: <https://doi.org/10.30464/jmee.00300>
- [5] H. Zhang, H. Fang, D. Zhang, X. Luo, and Q. Zou, "Forward Kinematics and Workspace Determination of a Novel Redundantly Actuated Parallel Manipulator," *International Journal of Aerospace Engineering*, vol. 2019, pp. 1–14, May 2019, doi: 10.1155/2019/4769174. Available: <https://doi.org/10.1155/2019/4769174>
- [6] "Design And Implementation Of Pose Recording System With Denavit-Hartenberg Method In A 6-Dof Robot Rotaric," *CORE Reader*, Available: <https://core.ac.uk/reader/577749510>
- [7] M.M.U. Atique, M.A.R. Ahad, Inverse Kinematics solution for a 3DOF robotic structure using Denavit-Hartenberg Convention, in: *Informatics, Electronics & Vision (ICIEV)*, 2014 International Conference on, IEEE, May 2014, pp. 1-5
- [8] R. N. Jazar, "Forward Kinematics," in *Springer eBooks*, 2021, pp. 225–311. doi: 10.1007/978-3-030-93220-6_5. Available: https://doi.org/10.1007/978-3-030-93220-6_5
- [9] M. N. Vu, F. Beck, M. Schwegel, C. Hartl-Nesic, A. Nguyen, and A. Kugi, "Machine learning-based framework for optimally solving the analytical inverse kinematics for redundant manipulators," *Mechatronics*, vol. 91, p. 102970, Mar. 2023, doi: 10.1016/j.mechatronics.2023.102970. Available: <https://doi.org/10.1016/j.mechatronics.2023.102970>
- [10] C.-K. Ho, L.-W. Chan, C.-T. King, and T.-Y. Yen, "A Deep Learning Approach to Navigating the Joint Solution Space of Redundant Inverse Kinematics and Its Applications to Numerical IK Computations," *IEEE Access*, vol. 11, pp. 2274–2290, Jan. 2023, doi: 10.1109/access.2023.3234104. Available: <https://doi.org/10.1109/access.2023.3234104>
- [11] S. Xie, L. Sun, Z. Wang, and G. Chen, "A speedup method for solving the inverse kinematics problem of robotic manipulators," *International Journal of Advanced Robotic Systems*, vol. 19, no. 3, p. 172988062211046, May 2022, doi: 10.1177/17298806221104602. Available: <https://doi.org/10.1177/17298806221104602>
- [12] D. Ge, "Kinematics modeling of redundant manipulator based on screw theory and Newton-Raphson method," *Journal of Physics Conference Series*, vol. 2246, no. 1, p. 012068, Apr. 2022, doi: 10.1088/1742-6596/2246/1/012068. Available: <https://doi.org/10.1088/1742-6596/2246/1/012068>